

# RCA Broadcast News

Volume 173

Broadcast and Teleproduction Happenings



**Going Up!**  
WDSE-TV Switches  
to CP

**KCOP-TV Adds  
HAWKEYE for ENG**

**Whirlpool Motivates  
With TV**

**Oklahoma State's  
New TV Center**

**CCD: Technology  
Update**

# And the Winner is . . .

# RCA

# HAWKEYE

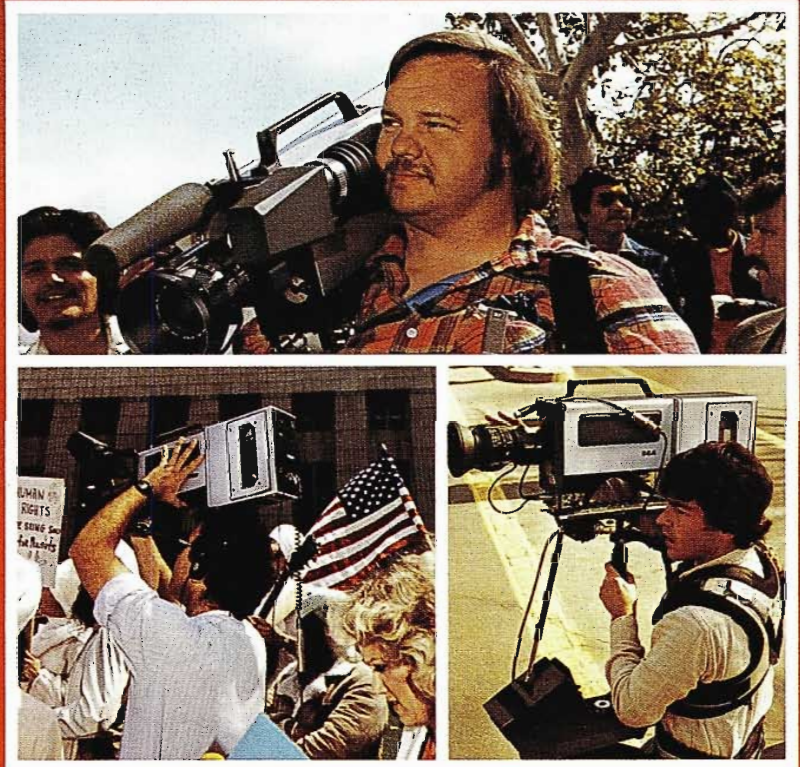

RCA has been awarded another EMMY for technological achievement—this one for the development of HAWKEYE, the system that first put the camera and the recorder together.

RCA pioneered this half-inch system; introduced the first commercial products; had the first "in use" systems in broadcast and teleproduction facilities.

The EMMY award for this outstanding development is most appreciated . . . and we thank The National Academy of Television Arts and Sciences, the broadcasters and teleproducers who encouraged us in the early developmental stages, and, most of all, our many HAWKEYE customers.

RCA, Building 2-2, Camden, NJ 08102

**HAWKEYE . . . The Half-Inch System  
That Makes The Difference!**

**RCA**

# RCA Broadcast News

Oct. 1983 Vol. No. 173

## CONTENTS

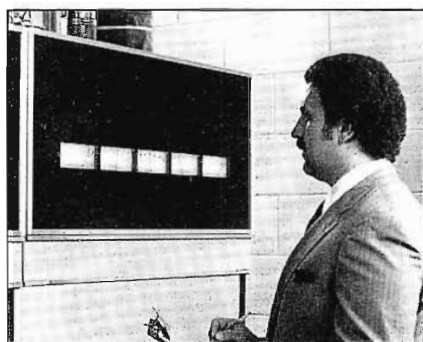

### 4 (Cover) WDSE-TV Upgrades with New Transmitter, Tower and CP Antenna

Public Channel 8, Duluth, Minnesota, switched to CP operation with the same ERP, but with a distinctly improved signal and better coverage. Viewer response was overwhelmingly favorable.



### 10 KCOP-TV Heats Up News Race in Los Angeles

Chris-Craft's independent Ch. 13 beefed up its news department; switched from film to video; added new vehicles and a complement of HAWKEYE cameras, VTRs and editing systems. The results—"a winning formula".



### 15 New Tele- communications Center for OSU

No newcomer to television, Oklahoma State University started modestly in the '60s; moved to color in 1971; built a reputation, and planned ahead. In 1983 the University opened its comprehensive new Center with broadcast quality production, post-production and teleconferencing facilities.



### 20 Whirlpool's Mil- lion Dollar Video Center Produces

Whirlpool corporation is effectively utilizing its well-equipped new video center, including TK-47 Automatic Cameras, for producing a range of quality training and motivational sales programs.



### 24 New RCA CCD Camera—A Technology Update

A new developmental camera using solid state CCD imagers was demonstrated first at the 1983 NAB and was hailed as a technological breakthrough. More details on RCA's Charge-Coupled-Device technology are presented.

### 30 Products in the News

New "Magic Tee" switchless output switching for parallel UHF transmitters provides many advantages, including increased reliability and faster switching.

# RCA

## KSKN-TV First To Use RCA HAWKEYE Equipment In All Phases Of Production

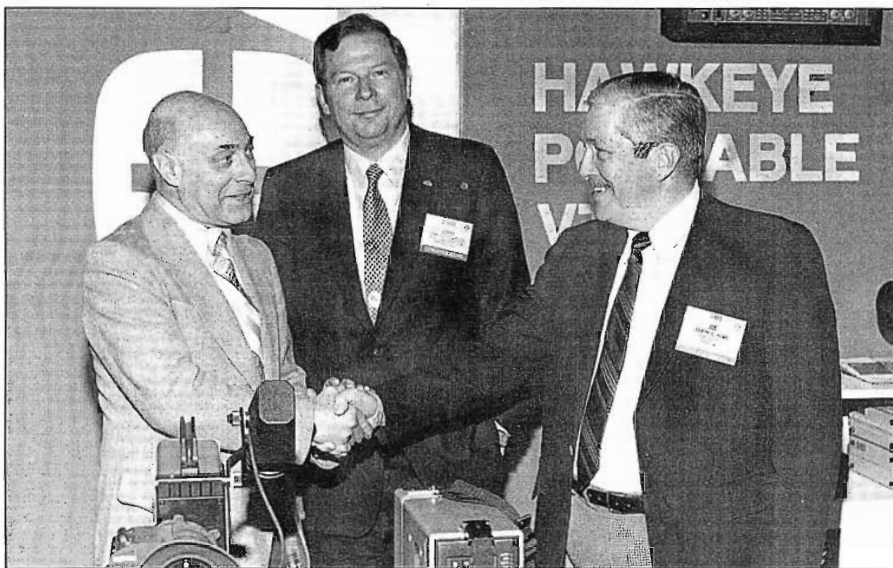

**HAWKEYE SALE ANNOUNCED.** Lee Schulman (left), President and General Manager of Broadcast Vision Television and Joseph B. Howe, Division Vice President and General Manager of RCA's Commercial Communications Systems Division, shake hands as RCA Group Vice President John D. Rittenhouse looks on. Mr. Schulman announced the purchase of 33 pieces of RCA HAWKEYE equipment for KSKN, a new UHF television station, scheduled to begin broadcasting in 1983.

KSKN-TV, a new UHF television station in Spokane, Wash., "should be the first station in the United States to go totally half-inch," according to Lee Schulman, President and General Manager of Broadcast Vision Television, the station's parent company.

Mr. Schulman announced the purchase of 33 pieces of RCA HAWKEYE equipment as part of the major equipment deal with RCA for the station, which is scheduled to begin broadcasting on Channel 22 with an RCA TTU-60D 60-kilowatt transmitter and an RCA TFU-25J antenna.

"We're going to originate, record and edit in RCA's ChromaTrak half-inch component format. As far as I know, we should be the first station in the United States to go totally half-inch. We're going to use it for news, field production and in the studio," Mr. Schulman said.

KSKN's order from RCA includes five HC-1 HAWKEYE cameras, three HR-1 portable recorders, 19 HR-2 studio VTR's and six HE-1 edit controllers. The order also includes a TK-29B telecine camera, a TP-7 slide projector, two TP-66 16mm film projectors and a TP-55 multiplexer.

For most studio production, Mr. Schulman said, the station will use HAWKEYE cameras, equipped with triax cable, to feed video that will be recorded on the HR-2 studio recorders.

Footage will be edited on the studio recorders, controlled by the HE-1 editors, with the final tape being played to air in ChromaTrak, Mr. Schulman said.

"Most news and field production will be done with the HAWKEYE camera-recorder combination, and editing again will remain in the half-inch format," he added.

## Two Post Corp. TV Stations Expand Operations With Six RCA TR-800s

The Post Corporation of Appleton, Wis., is increasing production and post-production operations at two of its television stations with six RCA TR-800 one-inch video tape recorders and other equipment valued at approximately \$1 million.

According to Elmo Reed, Vice President of Engineering for the corporation, the equipment also includes six TBC-8000 time base correctors, two TH-50A one-inch portable video tape recorders, a Grass Valley production switcher, a Grass Valley master control switcher and an RCA Multi-Rate Video Controller.

Three of the TR-800 recorders, in studio consoles are part of an expanded post-production operation at WOKR-TV (Channel 13) in Rochester, N.Y. that also includes the two Grass Valley switchers and a new CMX-340X editing system. Each of the TR-800s is equipped with a time base corrector, plug-in time code modules and a built-in Supertrack option to produce broadcast-quality pictures from tape running in reverse, forward or still.

WLUK-TV (Channel 11) in Green Bay, Wis. is also receiving three TR-800 recorders, two in studio consoles and a third in a transportable configuration for use in the studio and in the station's mobile van for live sports broadcasts. The editing capability of WLUK-TV will also be expanded with a CMX-340X editor and a Grass Valley 1600 AN video switcher.

## 5 Megawatt KLRT-TV To Go On-Air With Total RCA Package

A new UHF television station in Little Rock, Ark., is scheduled to be on the air this summer, following installation of RCA equipment valued at approximately

\$3 million.

Owned and operated by Little Rock Communications Associates, KLRT (Channel 16) is scheduled to initiate broadcasting in July with an RCA TTU-110C 110-kilowatt transmitter and a TFU-36JDAS antenna.

To receive programming distributed by satellite, the station is equipped with a five-meter earth station manufactured by Microdyne Corp., and marketed by RCA under a recent agreement between the companies.

The station's studio also will be operated with RCA equipment, including: three TR-800 one-inch video tape recorders, three TK-761 studio/field cameras, two telecine islands—consisting of a TK-29B telecine camera, a TP-66 16mm telecine projector, a TP-7 35mm slide projector and a TP-55 multiplexer—and audio, lighting and microwave equipment.

According to Dexter Merry, the station's Director of Engineering, Channel 16 will broadcast with 5 megawatts of power to viewers in the Little Rock-Hot Springs-Pine Bluff markets from a 1,200-foot tower atop Shinall Mountain.

### **Independent WFBT-TV, Minneapolis On-Air With RCA Package**

WFBT-TV in Minneapolis, Minn. has initiated broadcasting with an RCA transmitter and antenna, and studio equipment valued at \$2.5 million.

Owned and operated by Channel 29 TV Inc. of Greenwood, Ind., the independent UHF station went on the air with an RCA TTU-55C 55-kilowatt transmitter and a TFU-30JDAS antenna.

The equipment order also included five TK-761 studio/field cameras, four TH-200 one-inch video tape recorders, two switching systems, lighting equipment, microwave relay equipment, and a 7-meter satellite receiving station.

### **Major TK-47 Camera Acquisition For NBC**

RCA Commercial Communications Systems Division has announced an agreement with the National Broadcasting Company for the purchase of TK-47B automatic studio cameras that includes options for NBC to acquire up to 100 studio cameras.

The agreement calls for RCA to deliver eight TK-47B automatic studio cameras, for two studios in New York, during 1983.

NBC will be replacing approximately 100 RCA TK-44 studio cameras that are being used in the network's Burbank and New York facilities and in the five stations it owns and operates.

The agreement also covers triax versions of the TK-47B camera and options such as remote filter-wheel control and special video display units, as well as related equipment such as the TKP-47 automatic portable camera, and "smart" remote control units.

The acquisition of studio cameras is part of an overall NBC program to modernize and expand production facilities with state-of-the-art equipment.

### **RCA Markets Low-Power Television Equipment**

RCA's Commercial Communications Systems Division is marketing a line of low-power television (LPTV) transmitters and translators manufactured by Television Technology Corp. (TTC).

The non-exclusive marketing agreement was announced by Joseph C. Volpe, RCA's Division Vice President of Broadcast Transmission Systems, and Dr. Byron W. St. Clair, President of TTC, based in Arvada, Colorado.

The agreement allows RCA's domestic and international broadcast sales force to offer a line of eight low-power television transmitters and translators that

can broadcast an original program source or re-transmit a signal from any VHF or UHF TV channel.

Five of the transmitter models will operate in the UHF band and have power outputs ranging from 1 watt to 1 kilowatt. The three VHF transmitter models will have power outputs ranging from 10 to 100 watts.

"This agreement is in keeping with RCA's commitment to supply a complete line of equipment to broadcasters," Mr. Volpe said.

### **Unitel Video Adds Five RCA TK-47B Triax Cameras For Mobile Unit**

Unitel Video, a full-service television program production facility in New York City has added five RCA TK-47B automatic triax cameras to its 45-foot mobile production truck.

According to Al Geisler, Unitel's Executive Vice President, and Dick Klouser, President of Unitel Mobile Video, the five cameras were placed into operation in June on the company's "Star Truck".

### **New UHF KCBR-TV, Des Moines, Signs-On**

Owned and operated by Independence Broadcasting Corp., also of Des Moines, KCBR-TV (Channel 17) went on-air in 1983 with an RCA TTU-60D 60-kilowatt transmitter and a TFU-36JDA antenna. The major equipment purchase also included three RCA TK-710 portable color cameras, two TP-66 16mm telecine projectors, a TK-29 telecine camera, a TP-7 35mm slide projector and a TP-55 multiplexer, along with equipment for monitoring, microwave signal relaying, lighting and testing.

# Same ERP—BUT NEW CP SIGNAL MADE A BIG DIFFERENCE!

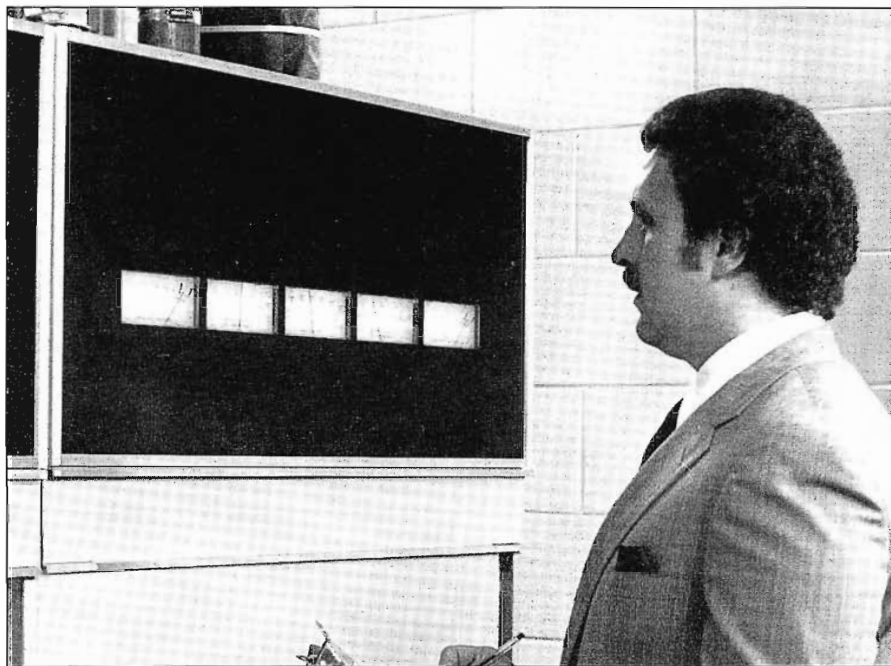

WDSE-TV Chief Engineer Rex Greenwell checks reading on one of his TTG-50H transmitters.

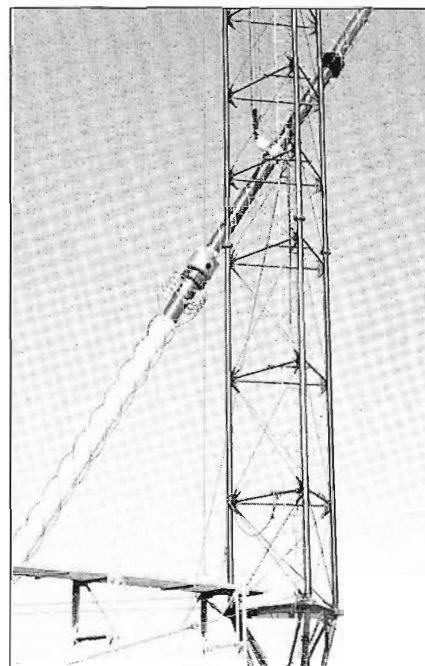

TCL-16A CP Antenna ready for lift-off.

When WDSE-TV, Duluth, Minnesota, began its evening broadcast schedule at 6:30 P.M. on November 1, 1982, it was expecting a reaction from viewers.

This broadcast marked the beginning of operations for TV-8's new transmitting system, including two TTG-50H 50 kW transmitters and a TCL-16A circularly polarized antenna. For General Manager George Jauss, Chief Engineer Rex Greenwell and numerous others at the station and in the community, it also marked the culmination of a major facility upgrading.

### Strong Viewer Response

The public channel, owned and operated by the Duluth Superior Area Television Corporation, had alerted its viewers to the coming change in broadcast signal. A questionnaire announcing the new service had been

mailed to supporters of the station, and these select viewers were requested to respond, indicating whether the new signal was improved, the same, or worse.

The anticipated reaction to the new broadcasting facility turned into a flood of some 2,000 responses, overwhelmingly favorable.

There was no change in ERP, since WDSE-TV had been operating at the authorized maximum 316 kW ERP. But there was a noticeable difference in the TV-8 signal throughout the area!

The new transmitting system was many years in planning; in obtaining necessary clearances from the FAA and FCC—and in securing funding. On-air since September 1964, the station was ready for a change in its transmitting plant. A major reason for the upgrading was

the need for improved coverage.

### Height Restriction; Hilly Terrain

Duluth sits on the shore of Lake Superior, with a hilly terrain. All of the television stations and FM stations have their antennas located on the "tower farm" atop a dominating hill which rises above the city. The tower height restriction imposed by the FAA is 800 feet maximum. Four TV towers (three commercial and WDSE) reach the maximum height (17 FM and 2-way radio stations also share the "farm" site with their antennas and transmitters).

The height restriction limits the quality of signal reception for a large part of the Mesabi Iron Range area which lies North of Duluth, extending beyond the normal "B" coverage zone. The belt of towns populating this

area receive marginal signals because of the hilly terrain separating them from the Duluth towers.

The objective of the new transmitting system, as stated by Rex Greenwell, was "to put

From the start, the results confirmed the expected increase in signal strength and coverage. As a "before and after" check, WDSE did have engineers take field measurements at two distant locations—Grand Marais

tures on their home TV sets. As noted previously, the viewer response was substantial and nearly 100% favorable. Many, particularly in the outlying areas commented on the improved picture quality from WDSE.

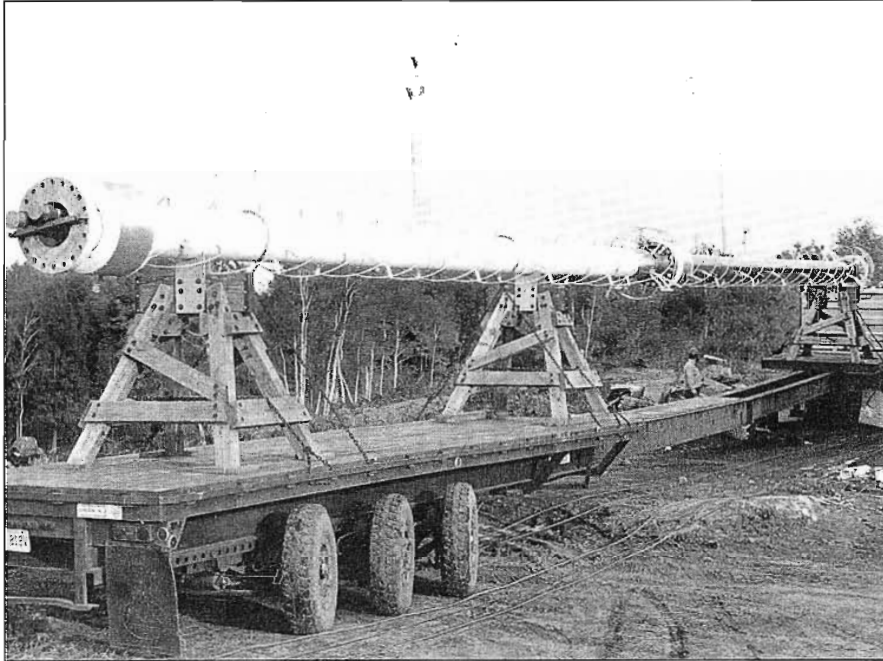

**Long trailer delivers two lower sections of 3-section TCL-16A Antenna for WDSE-TV.**

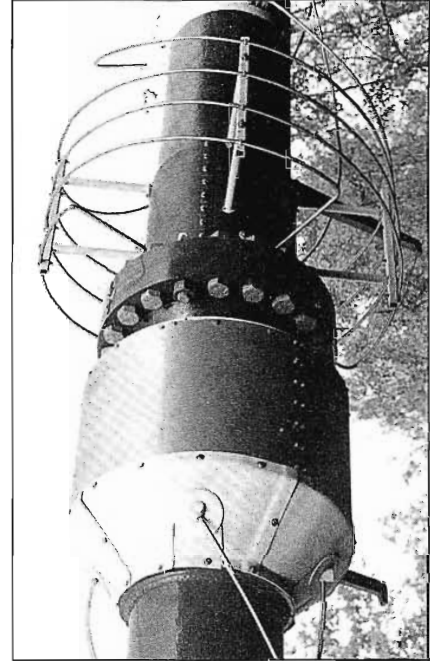

**Close-up of TCL-16A section connections and radiating coils.**

out the best signal possible, within the 800 foot tower height restriction."

### The CP Choice

Since circularly polarized signals would provide better penetration and hence more effective coverage of areas shielded by hilly terrain, Mr. Jauss and Mr. Greenwell decided early on to consider CP operation for their new transmission system.

The consultant, Jack Moffet, of Moffet, Larson and Johnson had thoroughly investigated circularly polarized technology and had recommended two such systems for another client, Capital Cities Broadcasting. In each case an RCA TCL antenna was specified, with good results. (WTVD, Durham, N.C., and KTRK-TV, Houston.)

and Grand Rapids (Minn.), both about 100 miles from the tower, in opposite directions. The result in both cases was an astounding +9 dB increase in signal strength.

A cable company at International Falls, 150 miles away reported that the new WDSE signal was so strong that it overloaded their receiver and they had to re-set the sensitivity scale.

### The Ultimate Test

In Duluth, closest to the transmitter, the Duluth School System called to advise that a TV set with rabbit ears in the basement of one of their schools could not pick up any station *but* TV-8's CP signal.

While some measurements were made to obtain a comparison between the old and new signal, the ultimate test was in how viewers reacted to the pic-

### TCL CP Antenna Specified

Why was the TCL Circularly Polarized Antenna selected by WDSE? Mr. Greenwell cites several good reasons: "It is a top-mount system. The antenna design is simple, with fewer connectors, pieces and parts—which should result in fewer maintenance problems.

"The measured patterns and circularity are excellent; the pattern is smooth, and the specs are good. And the TCL-16A is a highly efficient antenna, requiring less transmitter power to achieve the maximum ERP of 316 kW."

There have been no icing problems, Mr. Greenwell adds. With the TCL, the radiating element itself is heated with low voltage AC, he notes, so it in effect serves as the deicer. In addition, the feed line junctions and connections are covered, and

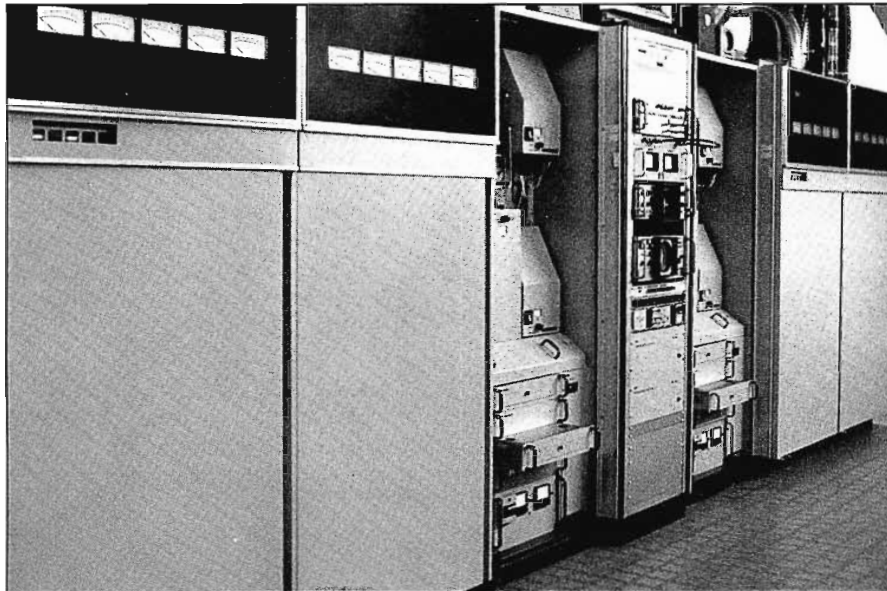

WDSE's two TTG-50H Transmitters are operated as Main/Alternate Systems.

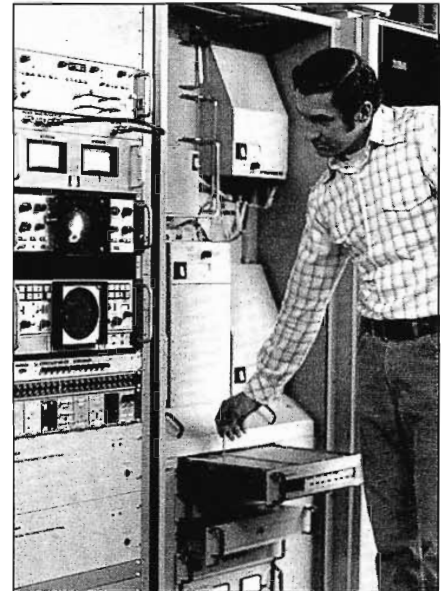

Engineer Alroy Kessler makes an adjustment, using video test rack conveniently located between the two TTG-50H Transmitters.

the lines are run inside the antenna which provides protection against damage and environmental conditions.

The WDSE-TV TCL-16 is omnidirectional, reaching across Lake Superior into Western Wisconsin. The antenna's beam tilt is 0.9°, with a Grade B signal extending out 65 miles. With the circularly polarized operation and the efficiency of the TCL antenna, the station is reaching viewers who were never covered before—some as far as 100 miles from the tower.

The three-section TCL-16A antenna is 128 feet long, and was delivered to the tower site on two trailers—one with the two lower sections connected; the other with the top section. The long trailer had to be assisted in reaching the antenna site. A crane followed the trailer to lift and move the rear so it could clear the turns.

### Twin 50 kW Transmitters

The TTG-50/50H Transmitters at WDSE are operated as a Main/Alternate system, with only one transmitter side on-air at a time. Transmitter output is 44.6 kW, which, with the 8 gain of the TCL antenna produces the maximum 316 kW ERP.

Changeover is made weekly, on Monday morning. The Main/Alternate operation provides both power and tube economies, Mr. Greenwell remarks. If the on-air transmitter should fail, the second side can be put on-air within 15 seconds.

An interesting aspect of this transmitter set-up is that in place of the combining cabinet which is used in parallel systems, TV-8 installed a rack for housing their complement of video monitoring equipment. This arrangement provides a direct view of the transmitter meters while making checks. The aural monitoring facilities are mounted in a separate rack.

When the moving van delivered the transmitter, with snow on the ground it was unable to navigate the final incline to the building, so the transmitter cabinets had to be transferred to a pick-up truck for the final 50 yard haul to the building.

As it turned out, the transmitters were installed and ready for operation long before the tower was completed.

The transmitters are remote-controlled from the studio via an MRC-1 Remote Control System which handles 32 meter readings and 64 commands. The

microprocessor-based system is programmed to provide a full range of data on the transmitters and the transmitter building environment and facilities.

### Transmitter Building

The transmitter building, with its faceless brown brick exterior, could easily be mistaken for a branch bank—except for its remote location and surrounding security fence. It is a plain, windowless structure, typical of newer transmitter buildings, with a single steel access door—a practical design which is more economical to build and which provides security and a better interior environment for the transmitter.

The new building and tower are situated about 2,000 feet from the previous location, which was a shared facility. The WDSE-TV slotted ring antenna was side-mounted on the WDSM (now KBJR-TV) tower.

Construction of the transmitter building began in December, 1981. Concrete for the tower base and anchor guys was poured at the same time.

### Tech Staff Handles Installation

As soon as the building was



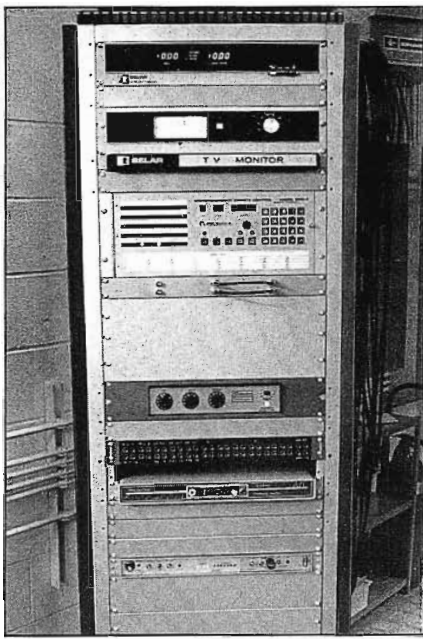

**Aural Monitoring Rack.**

under cover, the TV-8 technical staff began bending cable and cutting transmission line, preparing for installation of the TTG-50/50H transmitter. That installation was completed in April 1982, long before the tower was ready.

Handling the installation of the new transmission plant was no easy feat, especially considering that it was done by the WDSE technical staff of five, including Chief Engineer Greenwell.

In addition to the new installation, this small crew also had to:

- Man the old transmitter site.
- Handle studio equipment maintenance and production assignments.
- Maintain the Earth Station.
- Maintain the 5-hop

microwave system to St. Paul.

It entailed many long 18-hour days and a high degree of dedication to complete the project, Rex Greenwell vividly recalls.

### Building Features

The new building was designed to comfortably accommodate the TTG-50/50H transmitters, with ample space for the ancillary equipment. As might be expected for the cold climate location, the building is well insulated, with an R-31 ceiling insulation factor, and R-19 for the walls. The ceiling height of 15 feet provides a generous area for air circulation.

The building does not have a central heating system, but uses the heated air from the transmitters for inside heat via a ducting system which vents the

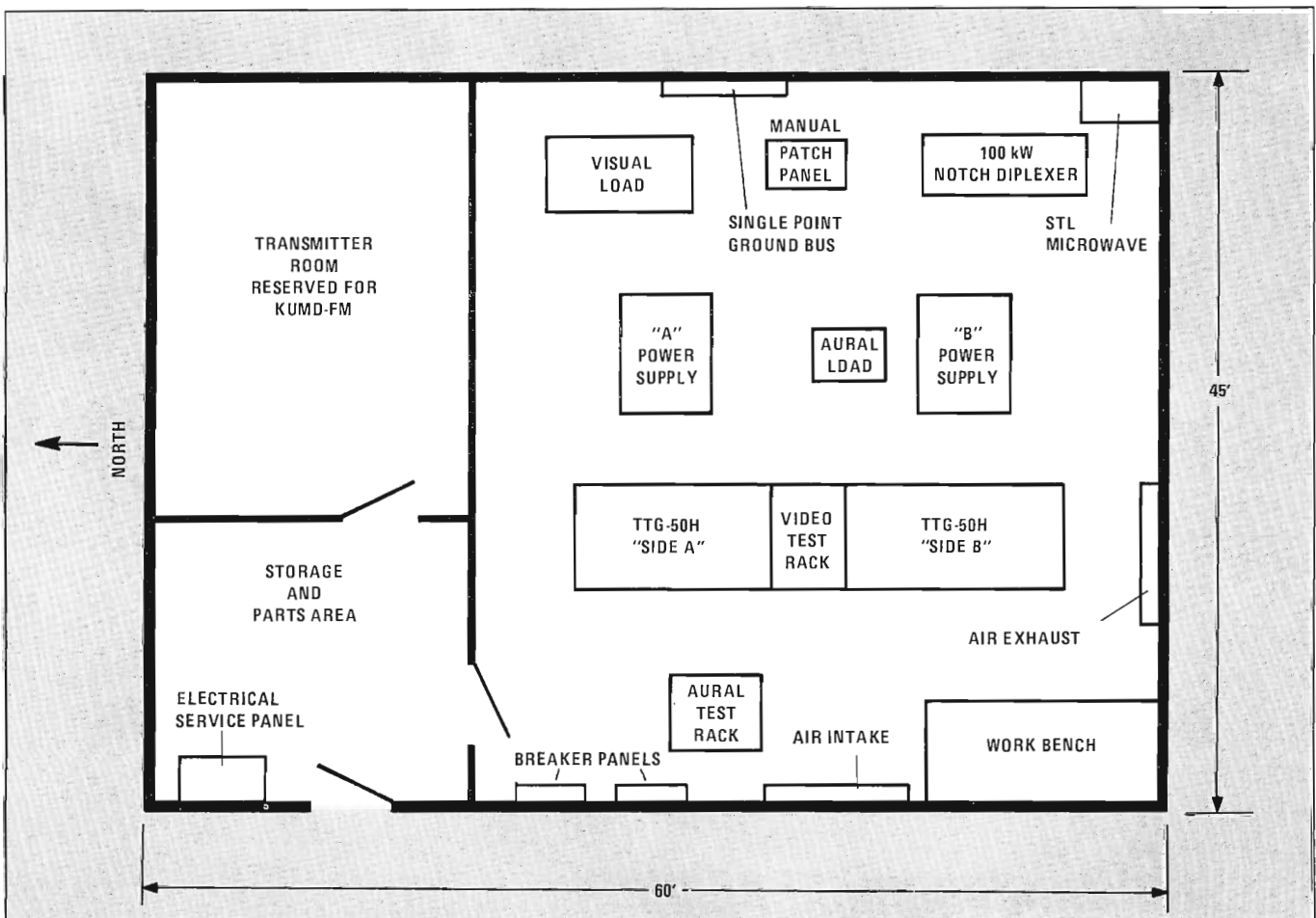

**Transmitter Building Floor Plan.**

## NEW CP SYSTEM

heated air outdoors when not needed for inside heat. (An auxiliary heating system is installed.)

Separate air-handling facilities are provided for each transmitter. To maintain a clean-air environment, the incoming outside air is triple filtered, with two furnace type filters and a bag filter.

A separate meter is used in conjunction with the air handling system, monitoring the status of the air filters to determine when the filters are sufficiently dirty to require replacing. Yet another on-site system provides for remote monitoring of the nitrogen pressure in the antenna line.

In addition to ducting the transmitters, WDSE also chose to vent the two power supply cabinets located behind the transmitters.

As noted on the floor plan, the aural dummy load is located next to the "B" side transmitter power supply cabinet, and the visual load is positioned near the rear wall. Both loads are self-contained, coolant re-circulating types. Mr. Greenwell notes that the VSWR on the TCL antenna is lower than on the dummy load—1.03:1 for the antenna and 1.05 for the dummy load.

### One-Point Grounding System

The 100 kW Notch Diplexer is floor-mounted along the rear wall. The motorized coax switching system is mounted in the customary overhead position, while the manual patch panel is conveniently mounted near the floor instead of overhead, making it more accessible.

Another feature of the building, Mr. Greenwell points out, is a one-point grounding system with a single common bus bar to which every piece of equipment is connected. This system provides an added safety factor against lightning, and avoids ground loops.

The University of Minnesota Duluth FM station, KUMD, is moving to the WDSE tower later this year. A separate space in the TV-8 transmitter building was

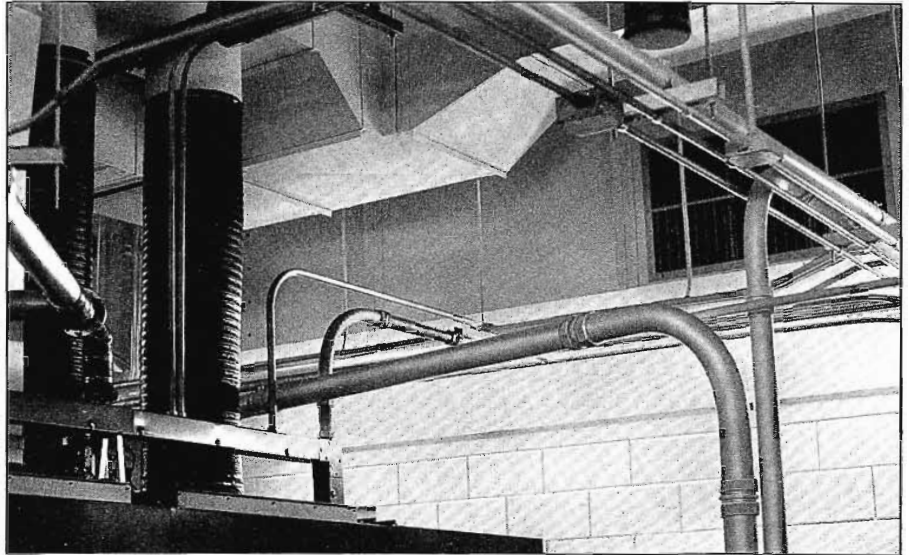

Ducting/air handling system maintains clean air environment.

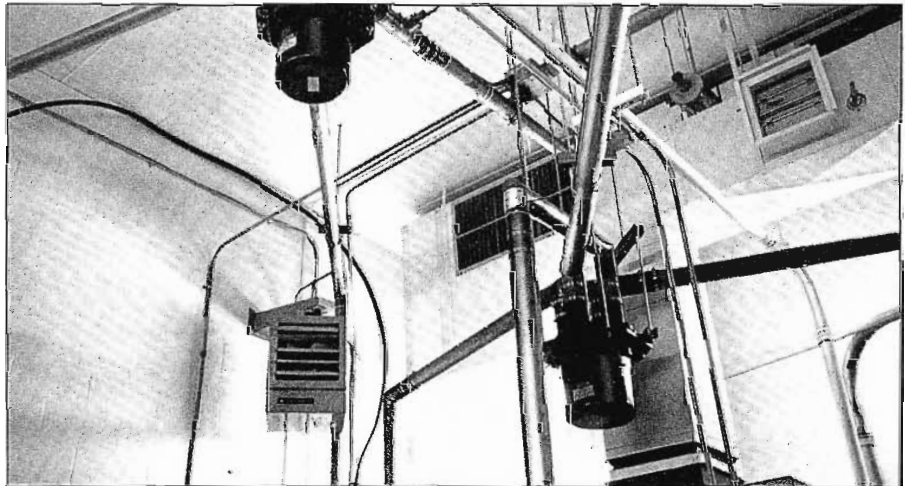

Motorized coaxial switchers are mounted overhead (above) while manual patch panel is floor mounted next to Notch Diplexer (below).

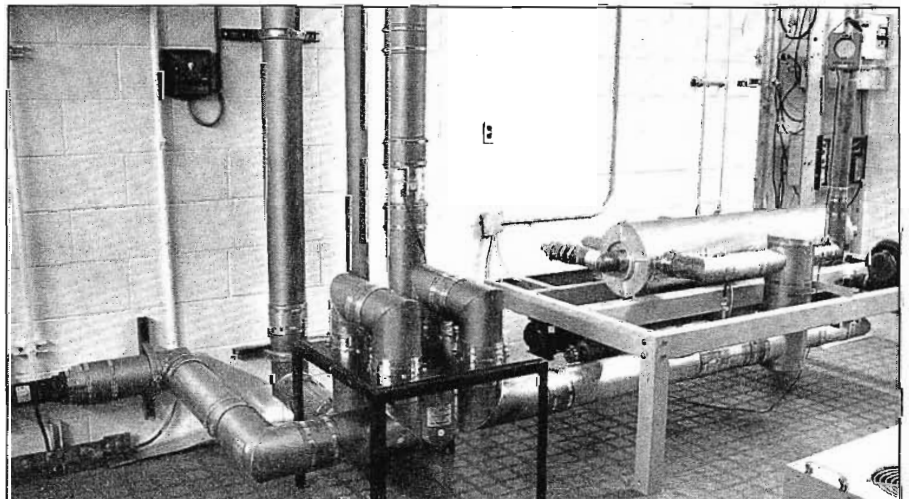



**Self-contained, coolant recirculating dummy loads are used. (Visual load above).**

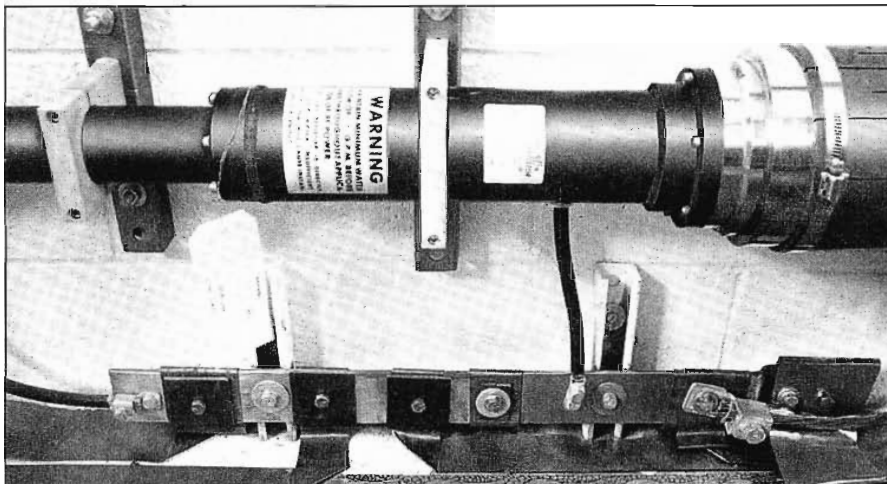

**One-point grounding system provides an added safety factor.**

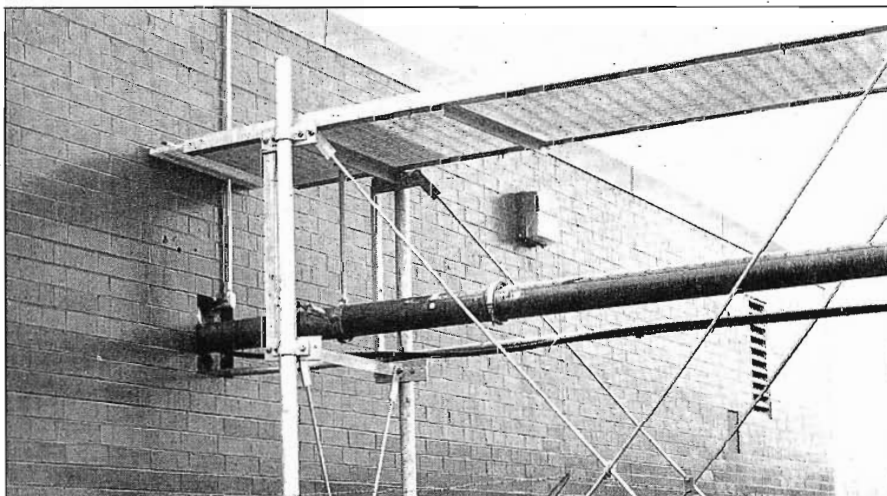

**Transmission line exits from austere transmitter building, protected by grid covering.**

provided for the KUMD transmitter.

## **Programming and Distribution**

WDSE-TV programs come from several sources. The prime time Public Broadcasting Service programs are received via the Westar IV satellite. Programs originated by KCTA-TV, the St. Paul PBS station, are beamed to Duluth on a multi-hop microwave system. Wisconsin Educational TV programs originated by WHA, Madison, are also microwaved to WDSE from station WLEF-TV, Park Falls, Wisc.

In addition to outside program sources, WDSE-TV produces several hours of local programming weekly. Among the regularly scheduled productions are: "Legislative Report"; "Doctors On Call", a panel show with viewer call-ins; "Venture North"; a magazine format series. The Duluth School System also produces some programs, as does area 4-H Clubs.

The WDSE-TV signal is carried north on a translator network which begins with a tower at Grand Marais, about 100 miles from Duluth. The program is rebroadcast on a UHF channel for the Grand Marais area. Further north, the Grand Portage area receives service by picking up the Grand Marais signal on another UHF channel, and the MacLean Hunter Cable TV Company in Canada picks up the signal from the Grand Portage tower and cablecasts it on the system that covers Thunder Bay, Ontario.

## **Recognition**

One exciting statistic which cannot be directly attributed to the new circularly polarized broadcast installation: WDSE-TV has moved into the select top tier of public broadcasting stations in the U.S., ranking #2 in overall prime time viewership. To maintain this position and to better serve the needs of the community, TV-8 is expanding its program origination effort.

# INDEPENDENT KCOP-TV BECOMES

**"With HAWKEYE and our Eagle vehicles, we have the most compact, least expensive, yet most capable news units on the street. Our field video is the best in town. We have a talented, cohesive news team. It's a winning formula."**

**Kerry Sullivan, News Director  
KCOP-TV, Los Angeles**

Up until last January, KCOP-TV's local news coverage was effectively shut down by 1:00 PM. Film shot by the station's two cameramen had to be sent to the processor, picked-up, edited and prepared for integration with the newsfeed from Independent Network News (INN) for an hour newscast aired at 10:00 PM daily. Film kept the station among the lowest rated of the four L.A. independents in news programming.

Then, in January, Channel 13 switched from film to ENG operation. And, KCOP became a strong contender in the "heated" race among independents for news viewers.

Was the station's status change a result of newly acquired state-of-the-art video equipment or the dedicated journalistic efforts of KCOP's newly expanded staff? Win Korabell, Director of Engineering, and Kerry Sullivan, News Director, agree . . . the two cannot be separated for one contributed to the other. But, Sullivan firmly insists Channel 13's new HAWKEYE recording camera systems have played an important role in recruiting talented news people and in generating a heightened sense of professionalism and competitive spirit among his entire staff. ENG operators, editors, reporters freely admit their personal pride in working for a station with what they say is the "best ENG equipment in town".

**Gary Brainard on HAWKEYE:**  
**"It's the ideal . . . light, compact, easy to use with the best picture. There's no comparison in film or video."**

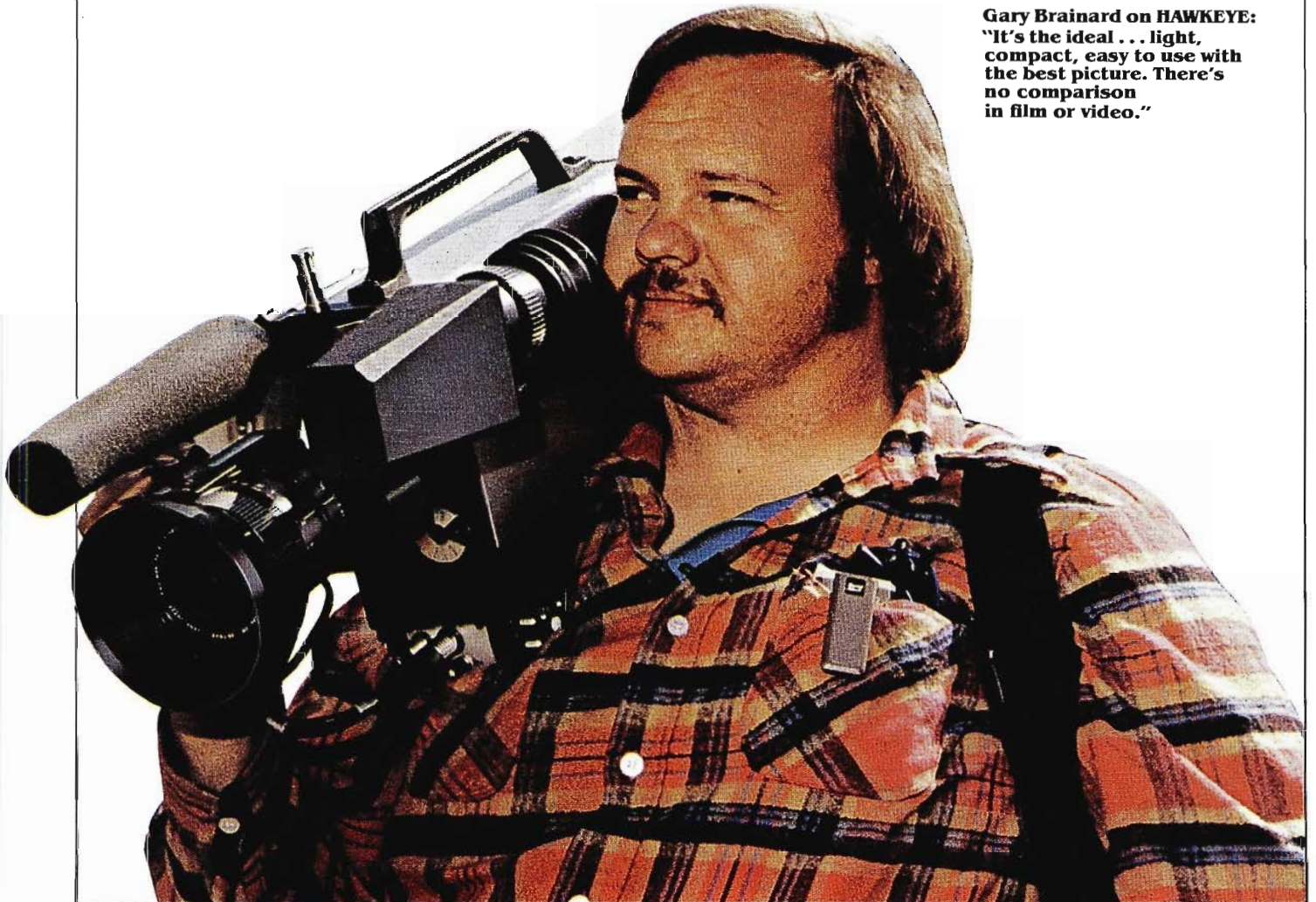

# COMPETITIVE FORCE IN L.A. NEWS

## HAWKEYE "... the Best System Available"

Early in 1982, when the decision was made to make KCOP-TV a competitive force in news among Los Angeles independent broadcasters, Win Korabell was chosen to spearhead the search for the right complement of equipment that would technically achieve the station's competitive objective. Backed by the total support of station management and a substantial investment commitment from Chris-Craft Industries (the station owners), Korabell began the process of equipment evaluation.

"I investigated all the options," states Korabell. He first considered two-piece systems using the 3/4-inch format. Cameras from nine different manufacturers were called in for in-depth system performance evaluation by KCOP engineers and field testing by the news department. Then Korabell turned his attention to the HAWKEYE recording camera system. "I was terrifically impressed with the picture quality, the mobility . . . it being a combo unit as opposed to a 3/4-inch set-up where you have two pieces."

In May, the entertainment division of KCOP began production on a special television event honoring Natalie Wood. The special required traveling across the country to videotape interviews with a number of top film and stage stars. Explains Korabell, "Since we would be shooting some of the stars in their homes, we wanted a video system compact enough so as to be as unobtrusive as possible." "Yet," continues Korabell, "we needed the best video quality possible for a production of this magnitude. I thought it would be a great opportunity to field-test HAWKEYE."

Korabell insists he is a careful person. Therefore, he says, the HCR-1 recording camera and HR-2 studio recorder were thoroughly lab-tested. He recalls, "The video recording quality of the 1/2-inch ChromaTrak format was so far above 3/4-inch . . . there was no contest. In my mind the difference was like comparing 16mm to 35mm film."

KCOP engineers separated the HC-1 camera from the recorder . . . tested it under low light . . . checked all parameters of performance before Korabell was convinced the camera met all the production criteria.

In the final edited master there were segments shot with the TK-46 studio camera and recorded on one-inch laid side-by-side with HAWKEYE footage. Asserts Korabell, "If anything, I thought the HAWKEYE segments were of better video quality. Right there and then, I became a believer."

Even after such a convincing demonstration of performance, Korabell continued his examination of other systems for use in KCOP's news operation. Evaluations were made on the Betacam and various other 1/2-inch one-piece systems.

Recalling his Betacam demonstration Korabell says, "At that time, the three-tube camera wasn't available. I was asked to evaluate the BVP-330 with the Beta recorder as an example of performance. I couldn't make that kind of judgment. Also there was some concern in my mind as to the recording format. It was modified three times."

Much more appealing was the ChromaTrak format. With RCA and four other major manufacturers adopting the format, Korabell believes it is becoming the "defacto standard". States Korabell, "Standardization was indeed an important purchase requirement. But, when we looked at the other systems, the picture quality just wasn't there."

A 30-year veteran of the broadcasting business, Korabell says, "I think RCA really knows how to make cameras. The HAWKEYE camera puts out a terrific picture. In low light it's more sensitive. It just delivers an overall better-looking picture. The HAWKEYE system covered all the criteria I needed for a major market like Los Angeles. It was my choice simply because it was the best system available."

## The HAWKEYE Package Chosen

Determined to transmit the best quality video possible, Korabell chose an equipment package that would allow KCOP to shoot, edit and air in HAWKEYE's 1/2-inch ChromaTrak format.

The station is equipped with three field systems. Two are HCR-1 recording cameras, each featuring a self-contained viewfinder with full metering indicators and playback capability, two audio tracks and a time code track fed by an internal SMPTE/EBU time code generator.

The third field system consists of a TK-710 portable camera and an HR-1 portable VTR with NTSC adaptor. Although this two-piece system is used daily for news assignments, the main reason it was selected was to give KCOP added flexibility. Should one of the HCR-1 recorders require maintenance, the stand-alone HR-1 could be easily connected to either HAWKEYE camera for a one-piece configuration.

The station owns two editing bays, each equipped with two HR-2 studio recorders and an HE-1 edit controller. Each edit system provides search modes up to eight times normal speed and permits simple, accurate frame by frame edits.

## HAWKEYE FOR ENG

All news stories, even those received from other sources in ¾-inch, go directly to air in the ½-inch ChromaTrak format. The ½-inch feeds are routed through the HAWKEYE HT-32 digital time base correctors to the control room where a half-hour of locally originated material is integrated with INN and Westinghouse newsfeeds for KCOP's daily 10:00-11:00 PM newscast.

### **HAWKEYE . . . Attracts Good Talent**

Joining KCOP-TV in September, Kerry Sullivan had the task of building a news staff of talented, enthusiastic people who would work well together.

Insists Sullivan, "Professionals look for certain signs. What is a company spending its money on . . . pizazz . . . or high quality, contemporary equipment? The investment we made in HAWKEYE equipment has paid off. People have taken our goals seriously. As a result, I've been able to bring

in good people by convincing them that we, indeed, are doing good work with state-of-the-art equipment and that they, indeed, will enhance their reputations and consequently their careers by being a member of our news team."

Starting with two cinematographers, one reporter, and a field producer, Sullivan has built a competent, cohesive news staff of more than 20 people. The staff now consists of assignment editors, writers, producers, ENG editors as well as an expanded field news team.

According to Sullivan, HAWKEYE has helped KCOP attain an excellent level of efficiency, allowing a three to five mix of operators and reporters for an average coverage of ten stories daily.

KCOP's three one-man ENG crews, equipped with dedicated gear and four-wheel drive AMC Eagle station wagons, are on the street for a full eight-hour shift each day. Shuttling back and forth

**On the run in cramped quarters: Andy Weintraub shoots Michele Babbitt's interview of L.A. Deputy District Attorney Roger Gunson.**



**"I've stopped asking our news people about the benefits of the system because all I hear are good things . . . there are just no negatives."**

**Win Korabell  
Director of Engineering**

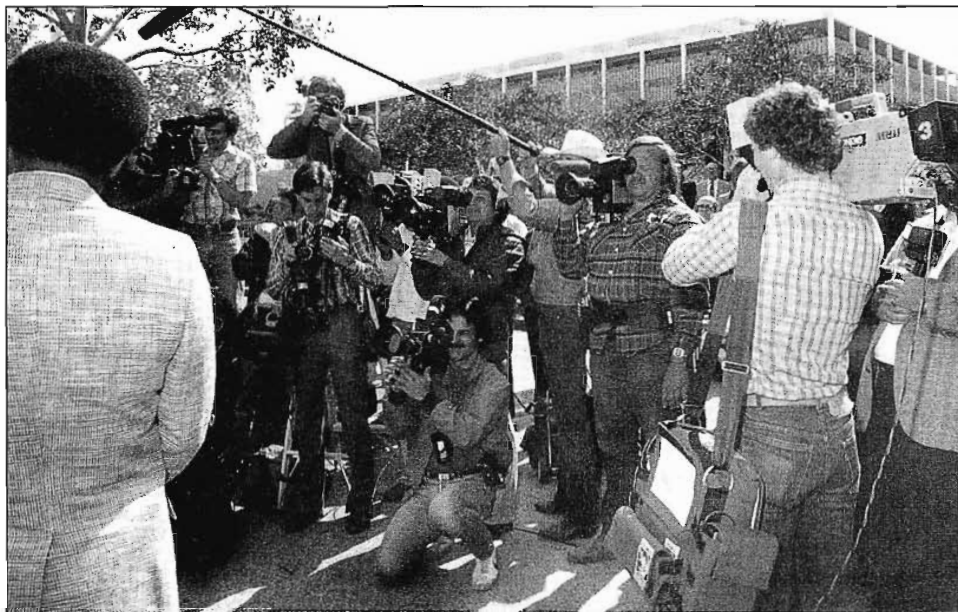

**Brainard with HAWKEYE handles this story single-handedly while film, video and even still photographers take more than a two-fisted approach.**

between the station's five reporters is made easier with a well-organized story plan and an efficient cassette transport system in which reporters act as couriers. But, operators agree it is the mobility and ease of operation of the HAWKEYE recording camera which makes getting in and out of locations in less time a big benefit. Reporter Jack Popejoy views the HCR-1's compact design as a real journalistic plus, "In tight locations you are right in there getting the close-ups that really make a difference."

Another boost for operational efficiency has been the reliability of the HAWKEYE equipment. Excited by the idea of the station being equipped with state-of-the-art ENG gear, Assignment Editor Marta Waller was still a bit apprehensive, "I was fully expecting to have one system down each day. But, we've had practically no downtime. The problems we have had were associated with the operators getting accustomed to equipment operation."

**HAWKEYE VTR and TK-710 camera keep KCOP in the ½-inch format while providing back-up support.**

Editing Supervisor Howard Campbell says both HAWKEYE bays operate 12 to 13 hours a day. "We haven't lost a story to downtime yet."

Kerry Sullivan adds, "My confidence in equipment reliability leads me to believe we will continue to have a very, very flexible overall system."

"I've stopped asking our news people about the benefits of the system because all I hear are the good things," states Win Korabell. "Now I ask about negatives. When you turn equipment over to operators, they can usually find something not to their liking. But, in this case, there are just no negatives."

## **"Best Looking ENG Pictures In Town" ... The Benefits.**

Kerry Sullivan says his instinct about the advantage of superb on-air quality has been confirmed by the collaborative relationship he's de-

**"Our newscast looks so good now. When we cut from our ½-inch story to a ¾-inch story of poor quality, it degrades the overall look of our news."**

**Win Korabell**



**Weintraub "right in the middle" of the Sikh protest story.**



**Howard Campbell:** "Frame accurate edits and independent search modes on each HR-2 saves a lot of time."

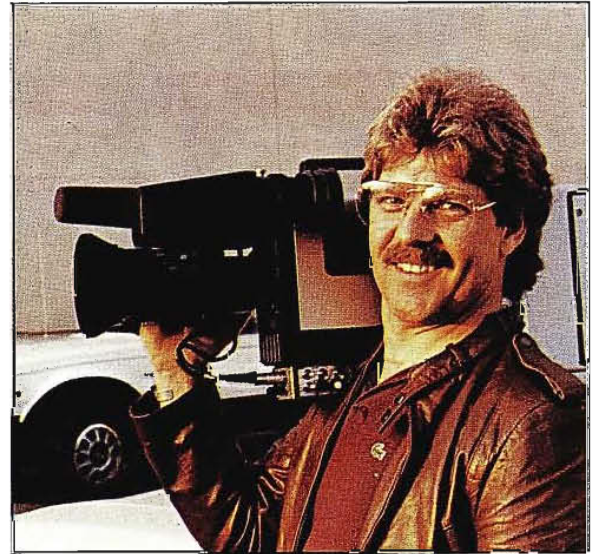

**David Overby on HAWKEYE:** "the best ENG equipment in town."

veloped with other stations in the Los Angeles area. He explains, "First you have to get out there and start covering the stories. Then when the broadcast community is exposed to a telecast that's high-grade video, you have it made. Swapping stories becomes an easier proposition, because other stations know they can count on you for quality. And that has made a big difference for us."

KCOP uses the 3/4-inch deck in their editing suite for trading tapes. Win Korabell calls it KCOP's "window to the world". With pride Korabell relates, "KCOP shoots the best looking ENG pictures in this town. When we want to send a story out to another station or one of the newsfeed services, we transfer the piece to 3/4-inch. I just don't see what all the outcry is about a single 1/2-inch standard! We can still send material out in 3/4-inch . . . and it's a better looking picture because we have technical control over parameters to start with."

What is disturbing to Korabell is the quality of some of the 3/4-inch feeds coming into the station. "Our newscast looks so good now. When we cut from our 1/2-inch story to a 3/4-inch story of poor quality, it degrades the overall look of our news. I don't know the answer . . . except that people using 3/4-inch have to start tightening up their technical parameters."

### **Commitment to the Viewer**

While many believe the video quality of 1/2-inch closely approaches that of 1-inch, there are those who ask: "Who needs the quality of 1-inch for news?" Win Korabell responds, "I believe we owe the viewer as well as the technical community the best possible picture quality we can deliver. In my judgment, I think we'd be taking a step backward by, as an example, going totally 3/4-inch or even

3/4-inch for airing. I've taken a close look at 1/4-inch and it's just not there yet. It has a way to go."

But, does the viewer really notice higher video quality coming over the airwaves? "Many times I think we underestimate the viewer," states Korabell. "It becomes an educational process. When you continually deliver a higher grade picture . . . especially when it appears side-by-side with something less . . . the viewer will sit up and notice the disparity."

News Director Kerry Sullivan agrees, "Our viewers tell us we look more professional now. A part of that is due to our journalistic approach and style, but video quality is very much related. We're trying, in every possible way, to deliver the highest quality video we can. All in all, that supports the overall image we seek to achieve . . . which is a modern, polished, professional, sophisticated look."

### **Revealing Strategy Ahead**

Coming from the bottom in independent news, KCOP's move up has been fast. Both Sullivan and Korabell agree HAWKEYE has helped . . . in talent recruitment, operation efficiency and in creating a more professional look and a better news product.

Probably the best evidence of their belief in HAWKEYE is their plan to double the station's base of HAWKEYE equipment this year.

"It is KCOP's long-range plan to be the number one ranked Los Angeles independent in news," reveals Kerry Sullivan. "We have a three-year plan to accomplish our goal." By then Win Korabell believes much of the industry will have jumped on the 1/2-inch bandwagon while KCOP will be reaping the rewards of taking a pioneering step into 1/2-inch technology early in the game.



## A NEW TELECOMMUNICATIONS CENTER FOR OKLAHOMA STATE UNIVERSITY

Oklahoma State University's new Telecommunications Center is a monument to fifteen years of patience, progress and planning.

Housed in a separate building on the University's Stillwater campus, the Center is a versatile, self-contained total service facility, with two studios, three post-production tape suites and a fully-equipped Master control room, plus two mobile units for on-location production work. In addition, the facility functions as headquarters and as origination/receive point for NUTN—National University Teleconference Network.

### **Education Television Services**

The Center is staffed and operated by OSU's Educational Television Services unit. ETS Director Marshall Allen notes that "television services" is an apt designation for his operation, since, along with its equipment complement and technical capability, the ETS unit is organized to provide concept-to-completion services.

### **Extended Planning Period**

"The fifteen-year wait for the new building worked to our advantage in many ways. We were able to design and equip a facil-

ity that will be as functional forty years from now as it is today," says Mr. Allen, who has been associated with ETS since 1967.

Wilbur Brakhage, Chief Engineer, who also started with Educational Television Services in 1967, remarks that even then there was a need for a new television production facility. At that time, the ETS operation was housed in the University's Broadcast and Journalism Department building, where the small studio used for live productions was located in a converted Chemistry Lab.

Even though the production output was limited to monochrome, ETS programs received recognition for their quality and content.

### **Switch To Color Made In 1971**

The first major change in the technical capability came in 1971 with the conversion to

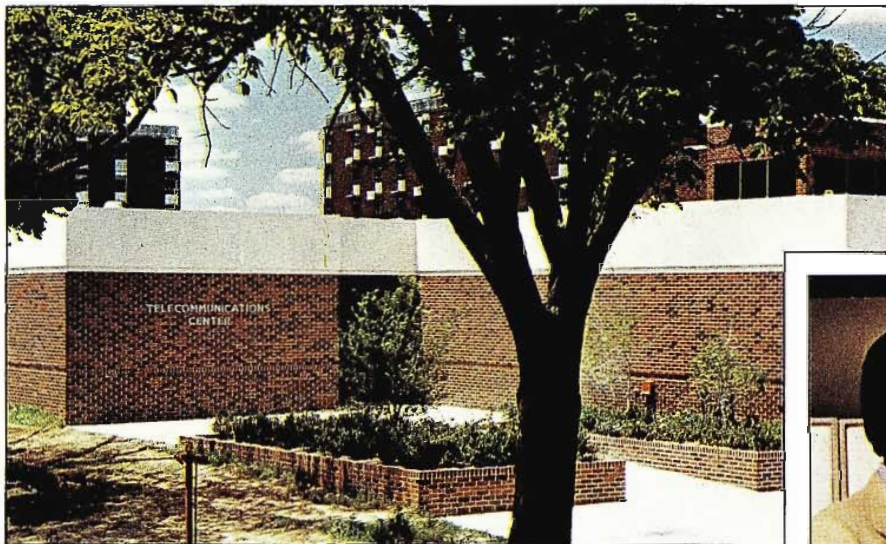

**Oklahoma State University's functional Telecommunications Center is designed for phased expansion to meet future requirements.**

**Marshall Allen, Head of Educational Television Services and Wilbur Brakhage, Chief Engineer, in Videotape area of Master Control.**



# NEW TELECOMMUNICATIONS CENTER

color. Two TK-44 cameras, color telecine and quad VTRs were added, along with new terminal equipment.

In adding the color equipment for the older facility, Mr. Brakhage noted, it was purchased with a view to long-term utilization. Consequently, with the move to the new Telecommunications Center in 1983, much of the terminal and switching equipment was able to be re-located, resulting in substantial economies. The use of computer flooring in the technical areas made it easier to install the cabling for the existing and the new equipment complement.

His commercial television experience (on the technical staff of KOCO-TV, Oklahoma City, and as a field service engineer with RCA) convinced Mr. Brakhage that in upgrading the ETS technical facility, broadcast quality equipment should be specified. This purchasing philosophy has been supported by the University in its subsequent equipment acquisition decisions.

## Equipped For Quality

A listing of the equipment complement provides an indication of the extensive high quality production/post-production capability of the ETS operation:

### Cameras

- 2—TK-47B Automatics
- 2—TK-44B
- 2—TK-76B

### Video Tape

- 3—TR-800 1-inch (with AE-800 Automatic Time Code Editing System)
- 1—TH-50 1-inch Portable
- 1—TR-60 Quad
- 1—TR-22 Quad
- ¾-inch Videocassettes
- ½-inch VTR's—VHS and Beta formats

### Telecine

- 1—TK-29B with TP-66 and TP-7 Film Projectors; TP-55 Multiplexer

### Video Switching

Production: GV-1600-7F

Post-Production: GV-1680-10X  
MC Routing Switcher:  
GV-32x16 AFV

## Efficient Facility Layout

The results of careful planning are evident in the layout of the Telecommunications Center. Television operations are visible, but isolated, so visitors can see what is going on without disrupting recording/production sessions.

The visitor's first view of the operation is from the reception area, where a glass wall provides a full view of the large Master Control room—which is also the technical center, housing the video tape, telecine, switching and video control complement as well as the terminal equipment racks for the routing, video and audio switching system and the earth station control facilities.

The main editing suite is also glassed in, and looks directly in on Master Control, providing editors with eye and voice contact with the video operators.

The terminal equipment racks line one wall of Master Control, and also serve as the separating wall for the adjoining repair facility, where the rear racks are readily accessible for servicing.

## Studio Design Features

At the opposite side of the building, separated from the Master Control area, are the two studios.

Studio A is 40' x 60' with a high ceiling, lighting grid; cyc, and double drape track. Smaller Studio B is 40' X 30' and has not yet been activated. It is now used for storage and prop construction.

The two studios are separated, with the space between used for storing the Field Production equipment between shoots. A large roll-up door makes it convenient to load and unload props and equipment.

Camera cables run under the computer flooring from Master Control, and terminate in

patch panels inside the studios. Wall-mounted receptacles are provided for microphones and audio. Mr. Brakhage also included a built-in 4-inch conduit to each wall of Studio A for special cable requirements, such as audio for telephone bridging for teleconferencing. This eliminates the need for stringing overhead wiring, or running cables all over the studio floor.

## Production Control

Adjoining Studio A is its Director Control room which looks into the studio. Directly behind is the audio booth, which is elevated, with a window providing the audio operator direct eye contact with the Director and the recessed wall of monitors. The audio mixer is a 16-input ADM 1600 Series II. Production Control A includes a Grass Valley 1600-7F video switcher and a Chyron character generator.

Production Control Rooms A and B are located side-by-side, but are separated by a small room. This arrangement is a design feature, since the recessed monitors from both studios extend into the separating space, which allows for heat dissipation and also makes the monitors available for service without interfering with production operations.

In addition to the 1-inch Editing Suite at the Master Control area, two ¾-inch Edit Rooms are provided. An additional ¾-inch and film edit room serves the University's Agriculture Information Bureau, a separate unit which is a heavy producer of videotaped material.

## Three Independent Air Handling Systems

Three separate air handling systems are installed in the Center:

1. Studio Area
2. Office Area
3. Master Control

In the technical areas, cool air flows under the computer flooring and returns via the drop

# NEW TELECOMMUNICATIONS CENTER

ceiling. The system maintains a humidity level of 38 to 45%, and 68°F. temperature, a necessity for proper equipment performance in the hot, humid Oklahoma summers.

## Small, Versatile Staff

Three operating units now comprise Educational Television Services:

Engineering—Wilbur Brakhage, Chief Engineer

Production—Bill Crane, Manager

Art—Roger Bolton, Manager (A fourth operating unit—Satellite Teleconferencing—is in the planning stage.)

It is a lean operation, with a full-time staff of only thirteen, supplemented by 24 part-time employees and students.

The Art Department is a complete in-house facility, set-up to handle set design and construction as well as graphics, illustrations and photography.

There are three Producer/Directors on staff, plus part-time assistants who handle cameras, audio and video operations and support functions. (The Producer/Directors' responsibilities include client contact; writing; directing; switching and editing.)

The technical staff includes two engineers and four student assistants.

## Expanded Production Capability

The new Center is designed for operational efficiency, with emphasis on maintaining high quality standards in production and post-production. The equipment and facilities reflect that commitment. "We estimate that production capability will double because of the increased efficiency afforded by the new surroundings," Mr. Allen states.

## Studio Camera Flexibility

The studio camera complement includes two new TK-47B automatic color cameras and four cameras from the older facility: two TK-44Bs and two TK-76B portables. All camera Re-

mote Control Units are located at the Master Control console. The Set-Up Terminal and Camera Processing units for the TK-47Bs are rack-mounted in the MC area. Both TK-47B cameras are equipped with Canon 12:1 manual zoom lenses with 2X extenders.

"We selected the TK-47B cameras because of the need for super quality for teleconferencing," Mr. Brakhage says. "We find that the automatic set up of the 47s is particularly useful, since our technical staff is limited. Also, since we use students in camera control operations, the instant set-up is a key

feature."

So far the cameras have been performing quite well, although the facility is still in the "shakedown" phase, so that many of the available camera features have not yet been utilized, Mr. Brakhage advises. For example, File and Recall memories will be valuable for later application.

## Multi-Format VTR Complement

One wall of the Master Control/Technical area is lined with video tape recorders and their related monitoring and test

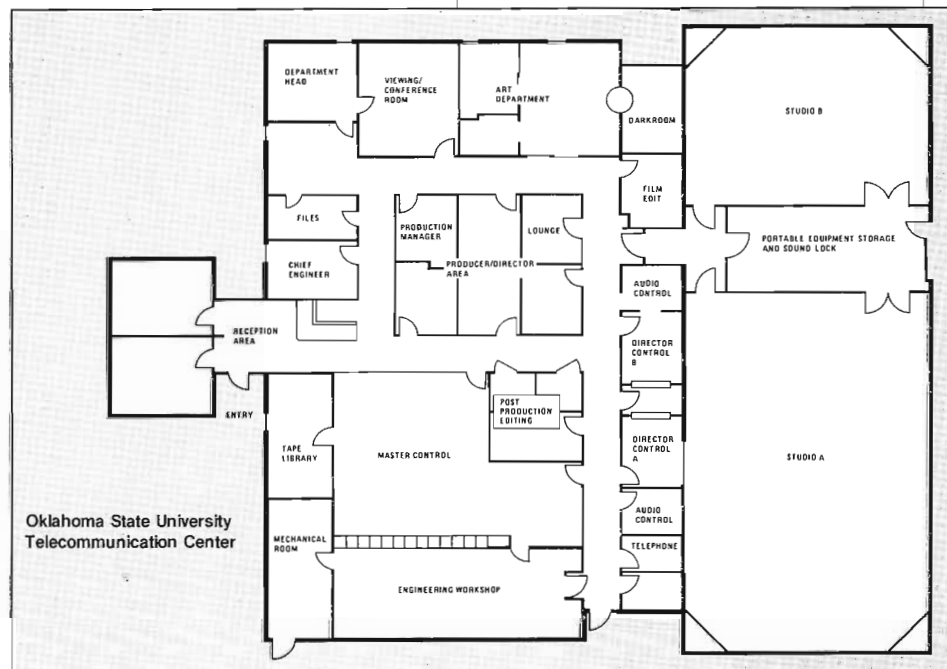

The Director Control Room, with machine controls, Production Switcher and graphics facilities, provides a direct view into Studio A.

facilities. Three new TR-800 Type C VTRs provide an effective 1-inch video tape capability. The TR-800s are controlled by an RCA AE-800 Automatic Time Code Editing system, with controls located in the 1-inch Post Production suite which looks directly in on the bank of tape machines.

"We're pleased with the TR-800s," acknowledges Mr. Brakhage. "They're versatile, excellent quality production machines.

The two quad VTRs—a TR-22 and a TR-60—were moved from the old facility.

The University has a large supply of ¾-inch and ½-inch (both VHS and Beta formats) videocassette VTRs. A complement of these machines is also in the Master Control area for dubbing tapes and for playback on the campus-wide closed circuit TV system. (Two channels are now in operation, and a third satellite feed is projected for the future.) As an indication of the demand for tapes, there are about 400 to 500 individual video tape check-outs per month by OSU students.

### **TK-29 Telecine System**

The TK-29 Telecine system in Master Control is a technical upgrading that has had a positive effect on the operation. "With the addition of the TK-29, we will be making more use of film in our production and post-production," says Mr. Brakhage. "The quality is excellent, and we are using the system for transferring negative film to tape for editing, and for transferring film segments for inserting into video programs."

"Compared to what we had been using, the TK-29's negative film handling capability came as a pleasant surprise to us," comments Production Manager Bill Crane. "We usually transfer to 1-inch tape and edit on-line. The TK-29 will save us a step in the process and give us a better quality tape for editing."

### **On-Location Capability**

Two mobile units are used

for covering remotes throughout the state, and the video and support equipment is packaged in suitcases and boxes for air shipments outside Oklahoma.

Engineering handles maintenance of the EFP equipment and instructs directors on operation and routine check-out procedures, but does not go on location with the crew. A typical shoot involves a crew of two.

Usually the TH-50 Portable 1-inch VTR and a TK-76B Camera are used for location shoots. With the addition of the TH-50, the TK-76 cameras have taken on a new sparkle, Bill Crane remarks. These cameras have stood up well over the years, Mr. Brakhage adds, providing excellent stability and picture quality, with minimal service needs. In fact, the original tubes in the cameras have yet to be replaced.

### **Teleconference Network Headquarters**

Teleconferencing is an increasingly used technique which was planned for in designing OSU's Telecommunications Center. The site is now equipped with a 7-meter Scientific Atlanta receive-only earth station, with a 10-meter up-link planned for the future.

The University has been involved in Teleconferencing since 1981, and the ETS center serves as headquarters for the National University Teleconference Network which includes 66 institutional members and the Smithsonian Institute.

In March 1983, just before the new Center was dedicated, the first live production involved a national teleconference on Earth Shelter Housing which covered 45 sites in 25 states. The program originated from the studio, using the TK-47B cameras.

### **Technical Support From Suppliers**

In handling maintenance and operational requirements with a small technical staff, support from suppliers is a "must" according to Mr. Brakhage.

"RCA's 24-hour parts service and Tech Alert are hard to beat," he says. "The Tech Alert Specialists are often able to 'talk through' equipment problems right on the phone. This service absolutely makes our job easier."

### **ETS Charter Extends Beyond Instructional TV**

Tracing the evolution of the ETS operation comes easy to Marshall Allen, since he has been involved since its inception. "We were viewed originally as simply an instructional unit. At that time we functioned as an A-V service, providing the traditional televised courses and lectures. Then there was a change in thinking, when the University recognized that there were more benefits to television in addition to its use as a classroom supplement."

ETS is a service of Oklahoma State University rather than being affiliated with a particular school or department, according to Allen. This broader charter permits more flexibility in covering a range of production assignments.

OSU is the land grant institution for Oklahoma, with an office in each of the 77 counties—and an obligation to provide state-wide service. This resulted in a charter for utilizing the OSU television facility that extends beyond the traditional instructional TV role.

Through the use of television, the University is able to make the public aware of what is going on in Stillwater.

### **On-Going Program Success Pattern**

An early production, "Candid Campus" has completed its eleventh season and is still going strong. This popular, informative weekly program is aired regularly by many of the commercial stations in the state. A series on the importance of mathematics funded by the National Science foundation resulted in 3,000 requests for tapes. Copies of the four-part series were provided to all State Department of Education Offices

# NEW TELECOMMUNICATIONS CENTER

in the U.S., and the series was incorporated in the WNET (PBS) daytime program schedule.

Since 1974, ETS has filled its broader role, producing numerous PSA's and other informational video tapes for the Oklahoma Highway Safety Department, the Oklahoma Department of Transportation, and the Department of Economics and Consumer Affairs. A current widely acclaimed series of TV commercials for the Highway Safety office center around the theme "good ole boys don't drink and drive".

## "Hands-On" Training Resource

The Center's modern technology makes it a valuable asset

to Oklahoma State University. Along with its basic function as a telecommunications center, the facility provides "hands-on" operational training for students. "Other universities tend to have students observe teachers at work. Here, however, students are an integral part of the system and our facility is not just observation-oriented," Allen remarks.

## Phased Growth Plan

The present 12,000 square foot building is Phase I of a long-range plan, with space reserved for building an adjoining structure. In addition, the present facility is also structurally designed to permit adding a second and third floor when neces-

sary. Further, the building was designed for sound isolation, with concrete poured for four separate units, which were later connected. This construction provides built-in sound locks, as well as providing the capability for expansion.

## An Investment In The Future

The new ETS facility is "the most modern educational telecommunications system in the Southwest and will be as functional 40 years from now as it is today due to the design of the building," Mr. Allen affirms.

"We view the Telecommunication Center as an investment in the future. And for us, the future is here."



One-inch Post Production Suite with AE-800 Time Code Editing system and video switcher, looks directly into Master Control, with TR-800 VTRs in background.



Multi-format tape facility includes TR-800 one-inch VTRs, quad machines and videocassette units.

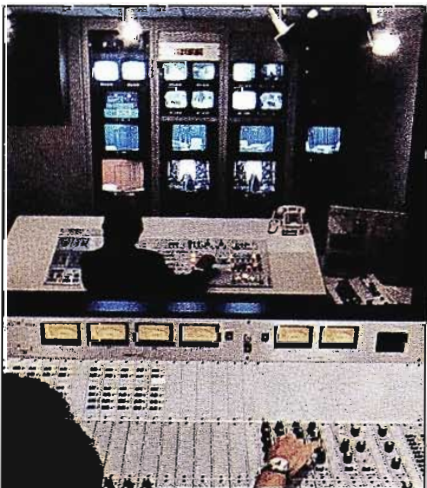

Audio operator has full view of Director Control Room and monitors.

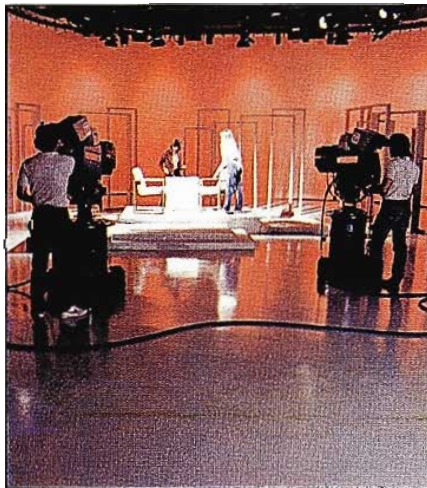

Two TK-47 Automatic Cameras provide super quality for teleconferencing.

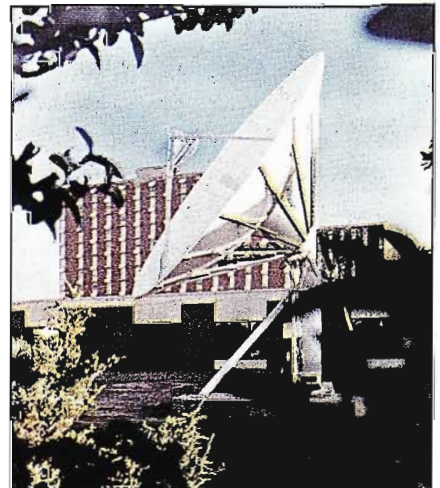

7-meter receive-only Earth Station is in place now, with a 10-meter uplink planned for the future.

# WHIRLPOOL

## EXTENDS COMMUNICATIONS REACH

"Ice-ability" is a new television program replete with high drama and slice of life realism. But you won't be seeing it on your home television screen. Because even though it sounds like an adventure epic set in the frozen tundra, it isn't. Rather, it's a skillfully done video sales training report on the features and benefits of Whirlpool's new refrigerator/freezer line. The program is representative of the high quality, professional television productions that the Whirlpool Corporation's Video Center in Benton Harbor, Michigan, is producing in their brand new corporate facility.

The Video Center is part of Whirlpool's 36,500 square foot John H. Platts Educational Center that was dedicated in December, 1982, and became fully operational in January. The total facility provides educational and training programs for dealers, service companies, distributors, builders and company personnel. The Video Center houses an impressive array of equipment that would be the envy of many a small independent television station.

### Teleproduction Inroads

Whirlpool management has always been committed to the need for educational training and, in addition to conducting "hands-on" workshop sessions, they had made inroads into teleproduction with the start-up of a small video operation in 1971.

Production was fairly limited, as was the equipment complement, but some very innovative and highly creative programs were developed. The value and feasibility of video training and education was apparent. When plans were formulated for construction of the new corporate educational center, a greatly enlarged and fully equipped video operation was a "must".

### Total RCA Planning, Design

RCA became involved early in the planning stages and worked with Whirlpool personnel in designing a functional and versatile production center. It was a carefully planned design that integrated all aspects of the teleproduction operation—complete camera, recording, production switching and editing facilities. RCA also designed the consoles and the production equipment configurations and worked with other OEM suppliers (Grass Valley, CMX, Conrac, Quantel) to deliver a complete production center, ready for turn-on.

The heart of the Whirlpool video system is the RCA Emmy-award winning, fully automatic TK-47 camera. Two of these advanced state-of-the-art cameras, each equipped with a teleprompter, are used in studio productions. Video recording is handled by three RCA TH-200 one-inch recorders. Augmenting that basic equipment array is a TK-86

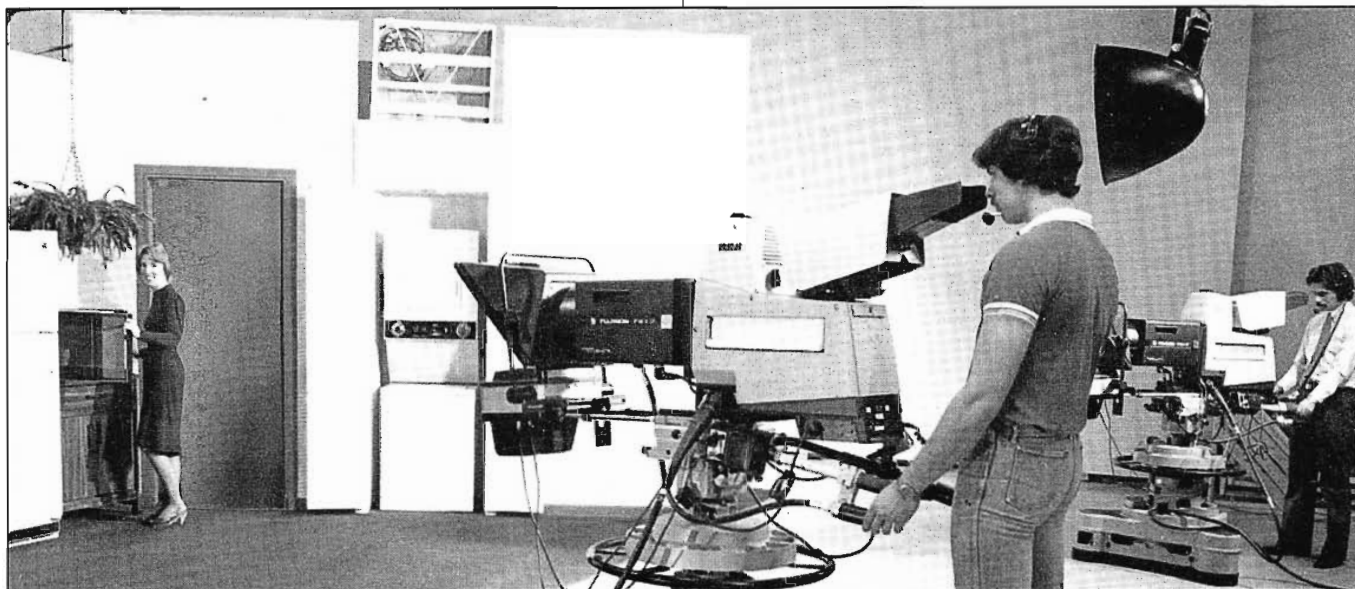

Two TK-47 are used in studio productions at Whirlpool's Video Center.

# MOTIVATES

## WITH NEW VIDEO CENTER

portable camera with a companion TH-50 field recorder, and a Grass Valley production switcher with a CMX-340A editing system and a Quantel character generator.

The complete system was assembled in RCA's Camden, New Jersey manufacturing plant where Whirlpool management and technical personnel had an opportunity to operate and check out the system before shipment.

The actual installation at the new Benton Harbor Video Center was supervised by RCA Tech Alert personnel. The installation was smooth and efficient and right on schedule for the December dedication to capture documentation footage of the first classes at the Educational Center.

### "Million Dollar Facility"

Bob Menter, General Manager of Video Education Services, is enthusiastic about the new Video Center. "We have a million dollar facility here and the quality of the programs that we will be producing will take a quantum leap forward because of the quality of the equipment we are using. The TK-47s produce superb pictures and with our one-inch recording and editing capability, we are getting end results that are just great. And the future potential of the video operation for the Whirlpool Corporation is phenomenal. As I see it, we'll become increasingly involved in providing chan-

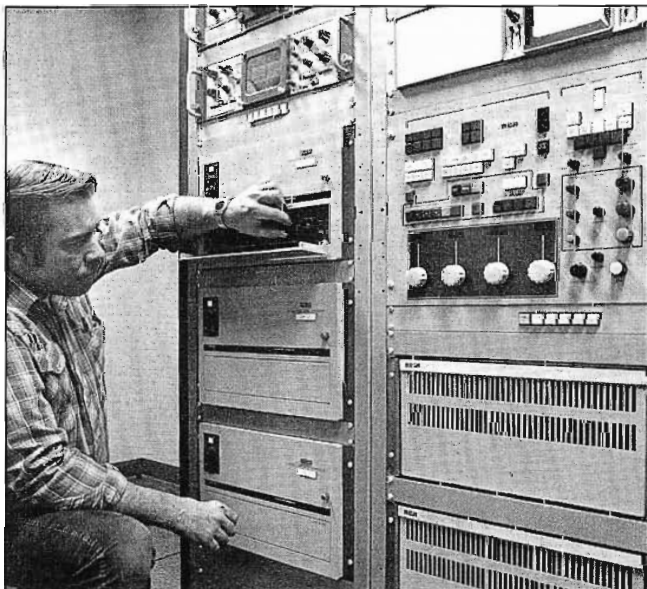

Engineer John Lepley makes adjustment to VTR time base corrector. TK-47 set-up controls are in large panel at right.

nels of communications from management to the employee . . . and perhaps from employee to management. That's an important link in the communications chain."

### Two Types of Programming

Currently, the Video Center is producing two distinct types of programming. The first, technical instructional programs, are quite simple in terms of production values. They are "nuts and bolts" programs that deal with the service and repair of Whirlpool products. These are simple productions that involve a dishwasher or a refrigerator, and video is shot to support pre-recorded narration.

The other type of programs that the Center produces are sales oriented. These are highly motivational, high production value programs that require a large crew—a technical director and operators for cameras, video, switcher and audio, plus floor personnel. Professional actors and narrators are also required for these full-scale productions.

### "World's Greatest Time-Saver"

John Lepley provides engineering services for the Video Center and he calls the TK-47 automatic set-up feature the "world's greatest time-saver". According to John, "With the manual set-up for a camera, a technician just can't get the kind of pre-



Producer/Director John Butler mans switcher in production control. Remote control units for TK-47 cameras are two panels in foreground.

cision calibration that you can get with the TK-47 and its microprocessor. Even if he set it up manually, it would take him literally a couple of days to do it, and the camera would only be operating up to 75% of its capability. The '47 does it all—precisely—in minutes!"

Lepley has been doing considerable experimenting with the microprocessor in the TK-47 set-up panel. He has an optimum set-up which he retains in the memory and he programs two or three other set-ups for different camera "looks". This experimentation has given him a good feel for the TK-47, even to the point where he and the computer, according to John, "are on good speaking terms with each other."

Whirlpool plans to get Lepley even more familiar with the TK-47 technical training workshop at RCA's headquarters in Camden.

### **Complete Teleproduction Facility**

A huge 40' by 60' two-story studio in the new center is home for the TK-47 cameras. The studio has a fully-equipped grid lighting system with 112 instruments, computer controlled from a theatrical style Electro-Control lighting console. There are both hard and soft cycs provided as well as a chromakey blue drape. Studio control is located in an adjacent room. It is equipped with a Grass Valley switcher, a teleprompter headend, audio system and controls, remote controls for the cameras and VTRs, and all of the associated monitors.

An adjacent room houses the three TH-200 one-inch recorders, equipment racks containing distribution panels and the SCU (set-up control unit) for the TK-47 cameras. A touch of a button and a complete camera set-up can be accomplished in minutes. The SCU can then be delegated to the second camera and the same quick procedure is followed. Both cameras are then technically identical for the ultimate in video consistency. And that consistency of performance is a key feature for John Butler, Producer/Director.

### **Continuity of Performance**

"Matching the two cameras is an easy task," comments Butler. "I'm not an engineer, but between the automatic set-up controls and the video control panels, I can match the cameras perfectly, take a break for lunch, come back and they are still right on the button. And that's the true test of a pair of cameras. The ability to shoot segments out of script continuity over a several day period, and yet maintain continuity of performance in resolution, colorimetry and white balance. The '47s have done a magnificent job for us. They have compensated for human errors all along the way. The work we are doing now is the best we've ever done and I attribute a great part of that to our new video equipment."

### **Complete Editing Capability**

The editing suite contains another Grass

Valley switcher with CMX editing controls. Also included in the equipment complement is a Quantel character generator. The CMX edit controller can take control of the total function and remotely operate the switcher for routine transitions, cuts, dissolves, wipes and keys. In addition to storing edit decisions on a disk, a hard copy printout is available for off-line editing.

Rounding out the facility is an engineering shop area, an announce booth, two fully equipped dressing rooms, and several administrative offices.

### **Business Meeting Programming**

Presently, the Video Center has scheduled between 12 to 15 major productions for 1983, and they are already expanding beyond programs developed solely for educational training. They recently completed taping and editing special programming for a Whirlpool major business meeting in Chicago. A unique aspect of the meeting was the use of the video tapes in an interactive way with the speakers. Some 40 RCA 13" color television sets were set up around the meeting room to provide combination live and taped presentations. Everything was very carefully programmed, right down to taped "coffee break" announcements.

### **Serving Communications Needs**

Bob Menter is enthusiastic about the versatility offered by the new video equipment. "The consistency of the TK-47, the major move up in quality from our former 3/4" cassettes to the one-inch format, the dynamic tracking capability that the recorders provide—they are all combining to give us immediate benefits in visual quality and in technical quality.

Our primary objective right now is to provide good programs for our training managers, for our sales and technical personnel. But as our staff grows, I can see us serving more of the corporation's communications needs. We have the equipment and the capability to do it. And looking even further down the road, I can see where we can ultimately provide video communications links—teleconferencing, if you will—between this location and other company facilities. The possibilities are unlimited."





TK-86 camera and TH-50 VTR are used for "on-location" shoots like this one in technical training room.

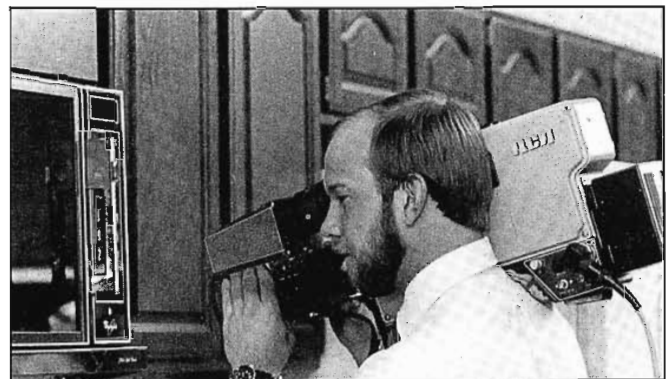

(Top) Three TH-200 one-inch video tape recorders are checked out by Bob Menter, General Manager of Video Education Services.

(Bottom) Versatile TK-86 moves in for tight shot of microwave oven controls.

"Corporate communications is entering an exciting era . . . it's going to be a vital part of doing business."

. . . Hank Bowman  
Division Vice President  
Corporate Education



### On the Value of Video

"Our Video Center is an essential part of our educational program. It provides us with the medium to extend the reach of the 24 educators that we have instructing here at the Educational Center. It also gives us the visual capability to effectively demonstrate how our products work. These are the kinds of things that you can't demonstrate in a typical training environment—how a dishwasher pumps water and circulates food soil out; how time lapse photography can show what happens to fruits and vegetables improperly stored in a crisper. Video is vital."

### On the Educational Center

"This is the 20th anniversary of our educational program. We started modestly and we have grown tremendously. Why have we done all this? Very simply, Whirlpool has a commitment to our customers because they are the ones that have made us successful. We are dedicated to our appliance retailers and builders who buy our appliances. We not only teach them how to sell and service our products, we teach them how to run an efficient, profitable business. We offer courses in widely diverse business subjects like people management, advertising, how to

compete in a given marketplace, how to set up financial controls.

The new Educational Center is our manifest expression of a continuing dedication to making sure that our customers—our dealers, retailers and builders—are successful and that they are best serving the needs of our end users, the consumer."

The most talked about new technological development at the 1983 NAB Convention was an RCA developmental camera using RCA's proprietary solid state CCD Imagers. The demonstration drew rave notices from trade press editors and from hundreds of broadcasters and teleproducers who had the opportunity to witness the camera's performance.

### **Broadcast Quality— And No Tubes**

The reasons for the attention given this camera were twofold. First, the camera employed no tubes at all as pick-up devices—the photo-sensitive elements were three 0.325" x 0.415" chips of silicon known as Charge Coupled Devices, or CCD's. And, second, the pictures obtained from the camera were mind-boggling to anyone familiar with the shortcomings of present-day TV cameras.

RCA's solid state CCD Imager completely eliminates many of the most annoying deficiencies of photoconductive tubes:

- *LAG*, which is a continuing problem even in the best imaging tubes, is completely absent from the pictures produced by the RCA CCD.
- *IMAGE BURN*, which can destroy expensive photoconductive tubes, cannot occur in the CCD. The RCA CCD can handle highlights in the order of 10,000 X without any retention or damage. Comet-tailing, the result of image burn from moving objects, is completely eliminated.
- *DYNAMIC RESOLUTION*, which is the amount of detail that can be seen in moving images, is far superior in the CCD Imager. The result is video that looks remarkably like film.
- *SENSITIVITY AND SIGNAL-TO-NOISE*,

## NEW RCA CCD IMAGER DEMONSTRATED AT 1983 NAB

R. N. HURST

RCA Broadcast Technical Training

which have been slowly improving over the years in pickup tubes, takes a dramatic jump forward with the RCA CCD. The demonstration camera produced pictures with S/N performance of approximately 65 dB, 7 to 10 dB better than the best of today's tube cameras.

In addition to the above, CCD's have essentially perfect geometry, absolutely no microphonics, no sensitivity to magnetic fields, and do not "wear out", as tubes do.

RCA long ago realized that solid state sensors could provide these advantages, and instituted an intensive program to develop these devices. The solid state sensor based on the Charge-Coupled Device principle was chosen as the most likely candidate for solving the problems of the older design pick-up tubes.

### **Successful Demonstrations**

The CCD camera is a joint development of three RCA units: Broadcast Video Systems in Camden; the David Sarnoff Research Center in Princeton, and Electro-Optics Division, Lancaster, Penna.

Since the camera is still under development and not yet available as a product, it was not shown in the main NAB exhibit area, but was demonstrated in a suite at a nearby hotel. Here it was shown to selected viewers on an invitation-only basis. In spite of this restriction, nearly 1,000 people saw the camera and went away astonished at the magnitude of the technological breakthrough they had witnessed. Often, after a demonstration of the camera, the 30 to 35 viewers in the suite would

stand and spontaneously applaud what they had seen.

The same CCD demonstration was conducted in conjunction with the International Television Symposium held at Montreux, Switzerland late in May of this year—with an equally favorable response.

### **Leadership In CCD Technology**

RCA has always been in the forefront of sensor development, from the iconoscopes of the 1930's to the modern photoconductive tubes of today. However, by the early 1970's, it had become apparent that tube sensors were approaching their limit; that further improvements in sensors would have to come through radically different technology. It was also evident that the then-new Charge-Coupled Devices could supply this technology.

An intensive cooperative engineering effort among three highly-skilled divisions of RCA was required to convert the seemingly-intractable problems of the mid-1970's to the glowing reports of 1983.

### **Four Approaches**

CCD sensors can be built in many different ways, but four basic approaches—called Frame Transfer, Line Transfer, MOS Array, and "Two-Story" Device—have received the most attention (Fig. 1). RCA's development teams settled on the Frame-Transfer approach, since it offers the greatest potential for high sensitivity, low output capacity, and the complete elimination of trailing smears on moving points of light.

The frame transfer structure has an image area at the top, and a storage area with output



## Robert N. Hurst

Bob Hurst joined RCA Broadcast Engineering in 1951, after receiving his B.E.E. degree from the University of Louisville.

He holds 18 patents in the fields of color television, video recording and digital television.

Mr. Hurst has written and presented numerous papers, and was a 1977 recipient of the Jesse H. Neal Award (the business press equivalent of the Pulitzer Prize) for a series of tutorial articles on digital television.

(See BROADCAST NEWS, Vol. #171 for a more complete biography.)

register at the bottom. The bottom area is shielded from light. The image is focussed on the upper area, and the resulting charges are transferred, once per field, to the storage area at the bottom.

The interline transfer CCD interleaves the image areas and the storage areas, placing the storage columns in between the active image columns.

The MOS array (which does not work on the CCD principle) is actually a large number of MOS capacitors which are read by an X-Y addressing scheme, in the same way that a RAM or ROM is read.

The Two-Story device is manufactured by overlaying a photo-sensitive layer on top of one of the other three architectures just described. Since it utilizes a photo-conductive layer, it retains the conventional pick-up tubes' disadvantage of image burn and lag.

## Frame Transfer CCD

As shown in Fig. 2, in a frame transfer CCD, the image is first formed on the Image Register ("A"), then, during the vertical interval, the charge image is transferred to the Storage Register ("B"). During the NEXT field, the charge image stored in the "B" register is clocked out line-by-line, using Output Register ("C"). Meanwhile, a new charge image is being formed in the "A" Register. The "B" and "C" Registers are optically shielded to prevent stray light from affecting the charges stored there.

Fig. 3A, B and C represent simplified graphic displays of how charge transfer works in a charge coupled device. The upper diagram (Fig. 3A) shows the two electrons, or charge packets, held in a potential well underneath the electrode with the positive voltage on it. In Fig. 3B, a positive voltage has been placed on the adjacent electrode, increasing the size of the potential well. In Fig. 3C, the voltage on the first electrode has been brought down to zero, resulting in a decrease in size of the po-

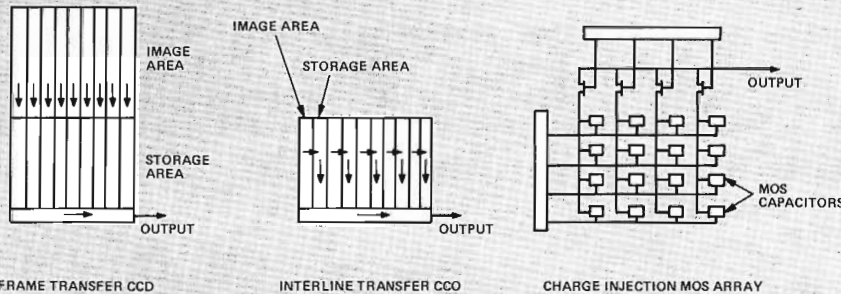

Fig. 1. Four basic approaches to CCD Sensors.

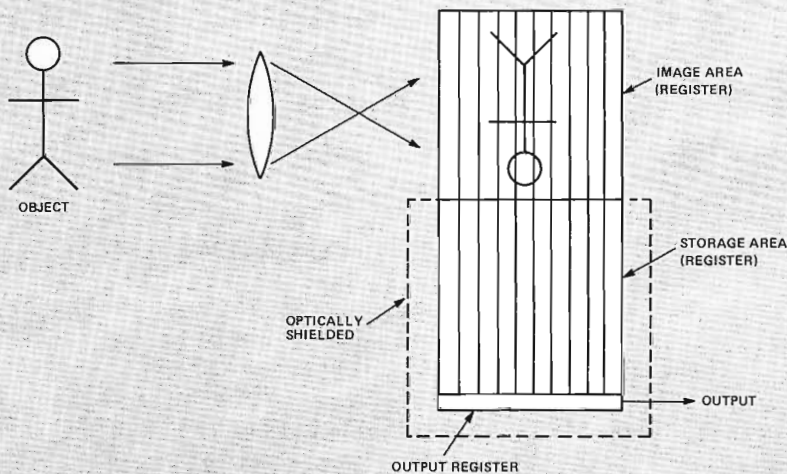

Fig. 2. Frame Transfer CCD.

tential well which, in essence, "bumps" the charge forward so that it is now underneath the new electrode. This is the basic mechanism that makes the CCD work.

Fig. 4 further illustrates the charge transfer process, using three staggered sets of clock pulses staggered in phase to move discrete charge packets along the CCD channel while maintaining their separate identity.

Fig. 5 is a simplified diagram of a Frame Transfer charge coupled device, showing

the A, B, and C Registers; the Imaging Register; the Storage Register, and the Output Register, along with the three sets of clock pulses required to operate those three registers. Also depicted are the channel stops which separate the adjacent CCD transfer channels from each other.

## Product Design Program

Following the successful demonstrations at NAB and at the International Television Symposium, and the resulting enthusiastic response, product development on the CCD camera is moving forward on an accelerated basis.

**Fig. 3A, 3B, 3C (Right):** simplified graphic displays of how charge transfer works in a charge coupled device.

**Fig. 4 (Below):** Charge Transfer Process.

**Fig. 5 (Opposite Page):** Basic diagram showing "A", "B" and "C" Registers of a Frame Transfer CCD.

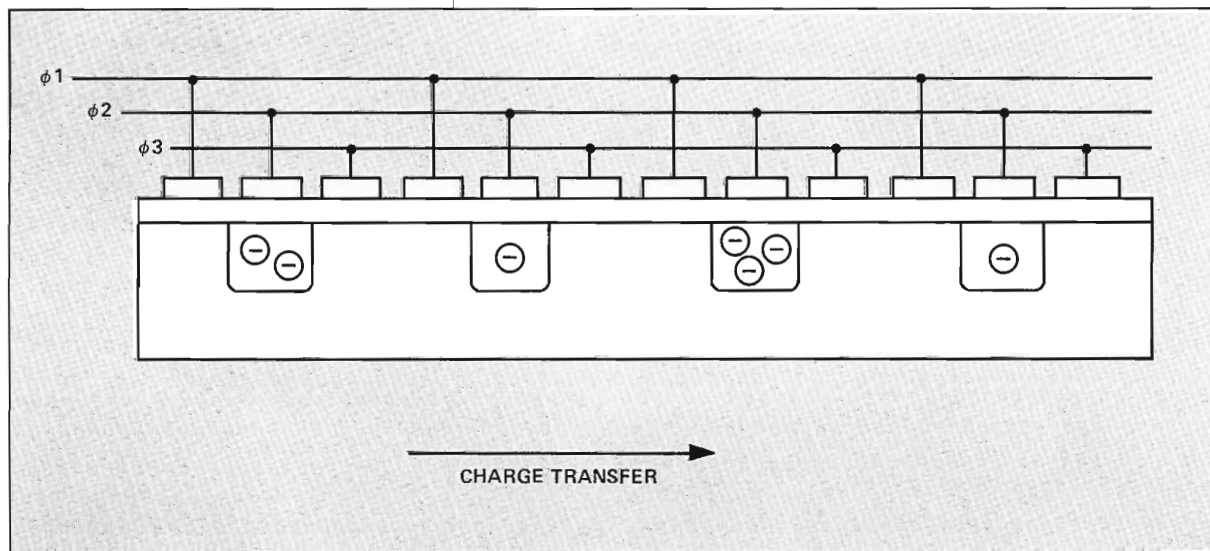
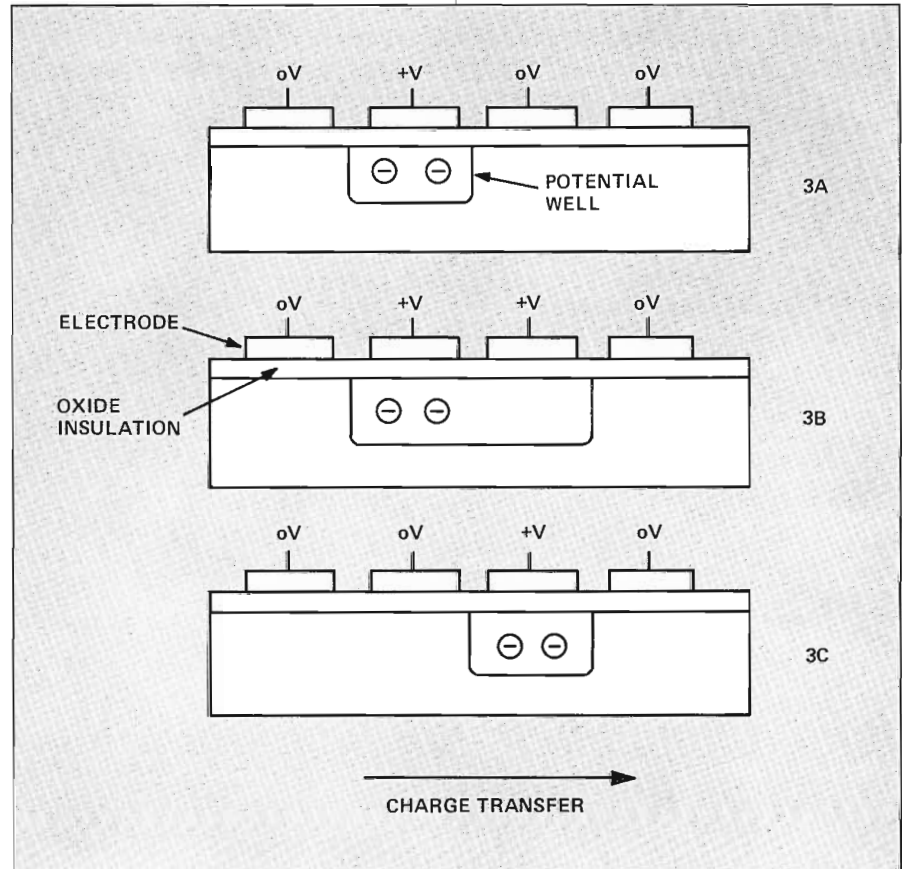

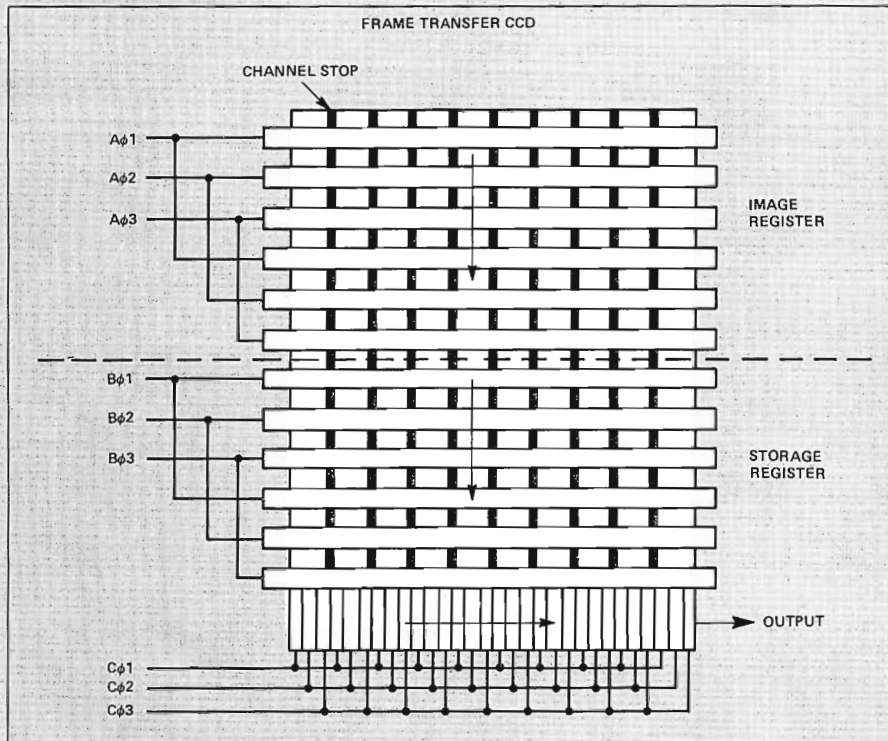

## ADVANTAGES OF RCA CCD IMAGER

- Zero Lag
- Zero Image Burn
- Essentially Perfect Geometry
- Zero Microphonics
- Not Affected By Magnetic Fields
- Essentially Unlimited Highlight Handling Capability
- Superior Dynamic Resolution
- Essentially Unlimited Life
- Superior Sensitivity and S/N

### Press Reviews

*Television Digest*, the prestigious weekly newsletter of the TV industry, was lavish in its praise of the new camera. In the April 18th edition, the normally-reserved publication said, "By far most talked-about single item was RCA's Charge-Coupled-Device (CCD) camera—a complete surprise. RCA said its proprietary development had conquered shortcomings of solid-state cameras—poor resolution and low light sensitivity—and could be used either for ENG or studio. 'It will change the industry the way RCA's TK-76 did in 1975.' said one observer." (Vol. 23:16 p.5).

*Broadcasting*, the weekly magazine of the industry, also used superlatives, and quoted freely from the impressions of industry authorities who had witnessed the camera's performance. In an article entitled "Technological Cornucopia at NAB '83", the publication accorded prime coverage for the new CCD camera, noting in part that "... the camera that was getting all the raves was in a

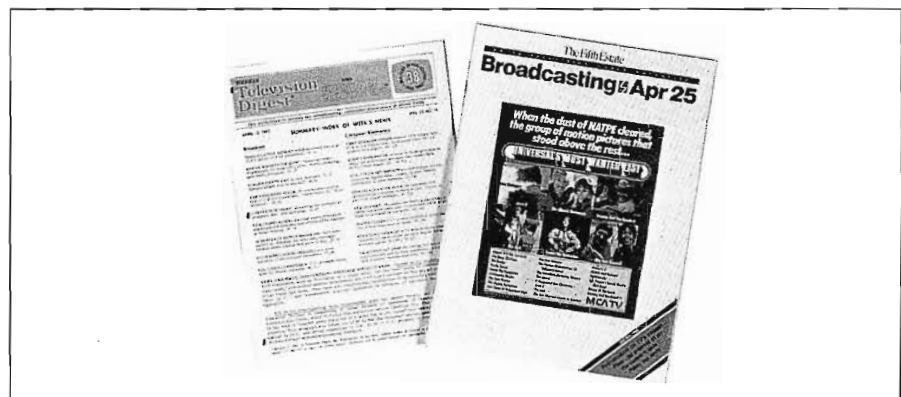

suite in the Riviera Hotel. That three-CCD prototype belonged to RCA, which has been working hard at the technology for several years. According to Fred Himelfarb, senior staff engineer, NBC, the camera was 'extremely impressive' and 'the best thing at the convention'. CBS's Richard Dunn echoed Himelfarb, saying that if RCA can transform the technology into the practical product, 'it could revolutionize the business'.

Reporting on technological developments at the International Television Symposium in Montreux, *Television Digest* (Vol. 23:23, p. 2) noted: "Most sensational was RCA's first public

demonstration of solid-state CCD color camera, shown privately during NAB (Vol. 23:16, p. 5). All observers we asked—including Flaherty, Barnathan, European broadcasters—agreed it was technical breakthrough, indicated they could hardly wait to get hands on it. Pictures were clean, crisp, with good contrast, adequate resolution—and no evidence of lag or smear whatsoever. Signal-to-noise ratio, even in relatively low light, was called 'incredible' by one engineer, is given as at least 65 dB."

## RAI Provides Vatican Coverage For Worldwide Pick-Up

During the week prior to Holy Week, Radiotelevisione Italiana (RAI) televised Pope John Paul II's "Opening of the Holy Door" ceremony held at St. Peter's Basilica in Rome using TK-47T automatic triax and TK-760 cameras. The celebration was carried to over 80 countries around the world via satellite.

RAI chose to use six TK-47T cameras to capture the pageantry of the ceremony and the detailed beauty and dramatic color of the Basilica interior. Outside, events associated with the ceremony were covered by three TK-760 cameras.

Automatic set-up terminals and camera controls were housed in three RAI OB vans located outside in St. Peter's Square. Franco Zeffirelli directed televised events from a control center located deep within the Basilica.

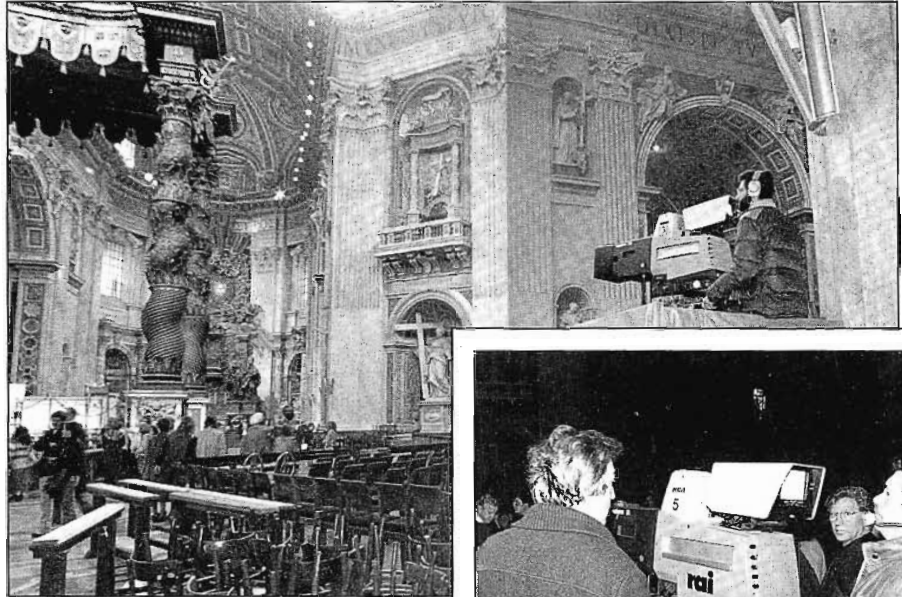

Beside the six TK-47's owned by Rome 1 and 2, RAI operates 200 TK-76's and 49 TK-760's at 17 broadcast centers in Italy's 25 broadcast regions.

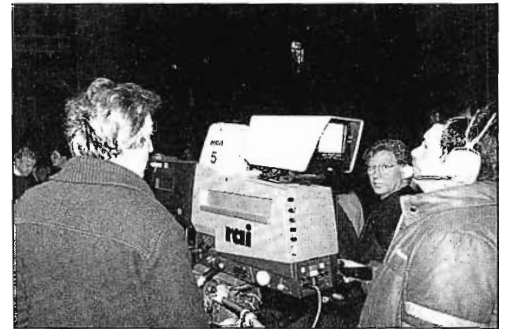

RAI TK-47 Cameras provide coverage of Vatican ceremonies.

## RCA PRODUCT LINES WELL REPRESENTED AT INTERNATIONAL TELEVISION SYMPOSIUM

Visitors to the RCA exhibit at the International Television Symposium in Montreux, Switzerland found a broad array of RCA cameras, video tape, and transmission products in NTSC, PAL and SECAM standards on display. Highlighting the show were RCA's new HAWKEYE HC-2 ENG/EFP Camera and HR-2A Studio Recorder, new TCR-10 Video Tape Cartridge machine, and the first European showing of the production model TKP-47 Automatic Portable Color Camera.

### The Pairing of Automatic Cameras

At the show, the TKP-47 operated with the TK-47B Triax Automatic Studio Camera to demonstrate the software compatibility of the two cameras. The portable uses the same set-up terminal, camera processing unit and remote control units as the TK-47B for precise colorimetry matching in mixed systems. Both are available for



The TTG-10, a transmitter for VHF Band III broadcasting. Available in all the world's color broadcast standards.

either triax or multicore operation.

### Newest Of The "Cart" Machines

The efficient, economical TCR-10, is designed to handle automatic station breaks, playback of individual program or

commercial segments.

The system's HS-1 Sequencer controls up to fifteen HR-2 half-inch HAWKEYE VTRs.

The TCR-10 permits programming of commercial breaks ahead of time. Local or remote control are offered. Built-in pre-roll provides an on-air picture

two seconds after a command function given.

**New Additions To The HAWKEYE Family**

Two new generation HAWKEYE products drew avid "hands-on" interest.

The HC-2 ENG/EFP camera offers rugged cast side-covers to provide extra protection against everyday field abuse (see "Products In The News", page 32).

The HR-2A is an enhanced version of the HR-2 half-inch ChromaTrak Studio VTR. The new unit incorporates feature improvements and significantly improved performance specifications for luminance, chrominance, differential gain and phase. It also features an improved reel servo, control track counter and a fast wind mode which moves tape up to  $\pm 20X$ .

**Demonstrating HAWKEYE Versatility**

In the studio area, the HC-1 ENG/EFP Camera was shown adapted for Triax remote control operation. With its triax adaptor the camera will operate up to 5,000 feet from its full-featured, joystick remote control unit.

The HC-2 Camera was demonstrated in a two-piece configuration with the HR-1 component ChromaTrak Portable Recorder. The HR-1 in this mode provides a built-in four-channel microphone mixer. In any mode, it allows monochrome playback through the camera viewfinder.

The HR-2 and new HR-2A HAWKEYE Studio Recorders and Players have standard video inputs and outputs and can operate as stand-alone units—for recording, playback or play-to-air applications. They can be controlled on a number of editing systems, including the HAWKEYE HE-1 edit controller and common ENG, EFP editing systems. Several systems were demonstrated at the ITS.

A system in which interfaces were used to carry the full quality of the HR-2's ChromaTrak component format through computerized editing, switching, digital video effects, and character

generation served as dynamic presentation of full component production.

**TR-800 VTR's Plus**

As further proof of HAWKEYE versatility, RCA demonstrated the HR-2 with two TR-800 one-inch Type "C" recorders. All three recorders operated with RCA's AE-800 editing system, a TR-800 accessory that provides sophisticated post-production at low cost.

**Transmission**

For VHF Band III broadcasting, RCA displayed the TTG-10 Transmitter, which is rated for 10 kW on CCIR Systems B, D, and K1 and I. The TTG-10 is a single tube combined amplification system, solid state to 400 watts.

RCA Astro-Electronics displayed a model of its 230-watt, K-Band Direct Broadcast Satellite. Two satellites are being built for Satellite Television Corporation and when launched in 1986 will be capable of broadcasting directly to the home. These will be the first DBS satellites to serve the U.S.

**RCA AT IREECON, AUSTRALIA**

The RCA Stand at the recent IREE Convention in Sydney featured a complete range of broadcast equipment, including several new products shown for the first time in Australia. These were the HAWKEYE II ENG/EFP Camera; the TKP-47 fully automatic portable production camera, and the TTG-10, 10 KW Band III VHF transmitter. Other products on display were the HAWKEYE HCR-1 Recording Camera; HR-2 Studio ChromaTrak 1/2-inch VTR; TR-800, Type C VTR, and AE-800 Automatic Time Code Editing System.

The TKP-47 Automatic Portable Camera is available for either multicore or triax operation, and utilizes the same automatic set-up controls as the TK-47 Studio Camera.

The TTG-10 Band III Transmitter is one of the first stereo-compatible transmitters avail-

able. Self-contained in a single cabinet, it is solid-state up to 400 watts and uses combined amplification into a single tube.

**UNITED NATIONS CONVERTS TK-47 CAMERAS FOR TRIAX**

The United Nations television program production center recently converted its two RCA TK-47 automatic studio cameras to operate with triax cable, which is used in the meeting rooms of the General Assembly and Security Council.

According to Martin Bunnell, Production Manager of the U.N. television operation, the RCA cameras could now be used to Broadcast meetings of those two U.N. bodies.

Mr. Bunnell said the RCA cameras will broadcast from the General Assembly building Oct. 24, when the National Orchestra of Spain performs as part of the United Nations' anniversary celebration. The U.N. was founded Oct. 24, 1945.

**NEW TELEVISION STATION IN LIMA, PERU BEGINS CP BROADCASTS**

TV Andina, a new television station in Lima is scheduled to begin circularly polarized broadcasting in 1983, following installation of an RCA transmitter, antenna and other equipment.

Owned by Andina de Radio-difusion S.A., Channel 9 will broadcast with an RCA TTG-30/30H 60-kilowatt transmitter and a TBJ-8A9S circularly polarized directional antenna, according to Dr. Fernando Barco, President of the company.

Valued at approximately \$3.5 million, the equipment purchase also includes three TK-47 studio cameras, a TK-29B telecine camera, a TP-55 multiplexer, a TP-7 35mm slide projector, two TP-66 16mm film projectors, two Grass Valley production switchers, audio equipment, a 45-meter support tower and a microwave relay system.

# "Switchless" Output Switching For UHF Transmitters

An exciting new technique for output switching is now available from RCA for use with parallel UHF TV transmitters such as the TTU-60D and TTU-110C.

This new "switchless" switching technique eliminates the need for complicated routing of RF "plumbing", and many coaxial or waveguide switches.

The new system accomplishes the functions heretofore performed by manual and motorized coaxial or waveguide switching arrangements, and offers these advantages:

1. Increased reliability
2. Faster switching (2 seconds versus 15 seconds for motorized switching and minutes for manual)
3. Remote controllable, from Studio or Transmitter Room Control Panel

The new "switchless switching system" is based on RCA's development of Aural Cavity Detuners and the application of "Magic Tee" theory for high power UHF television frequencies.

The Aural Cavity Detuner employs a simple knife-like blade which, when inserted into the waveguide aural cavities of the notch diplexer, detunes the cavities more than 1 MHz. Aural multi-

plexed with visual carrier can thus pass through the diplexer, eliminating the need for diplexer bypass switching if an aural power tube should fail.

The "Magic Tee" (sometimes also identified as a hybrid junction or waveguide side outlet Tee) has been used frequently in microwave applications for combining, splitting and routing. It is a waveguide section, with two input ports and two output ports. One output port is in the same plane as the input ports, and the other is perpendicular to them.

A key element of the "Magic Tee" combiner system is the Phase Shifter (A and B on the accompanying diagram). The Phase Shifter is a dielectric block with a slow propagation coefficient which is located inside a section of waveguide.

The dielectric block is usually "parked" at the side of the Phase Shifter waveguide, and is moved into a preset position within the waveguide to shift the phase of the two RF inputs to the "Magic Tee", thereby changing the path of one or both signals to the output ports of the "Magic Tee".

Operation of the "switchless switching" system for a TTU-110C Transmitter is shown in the dotted line area on the diagram. The outputs of the two visual klystrons are fed into a hybrid

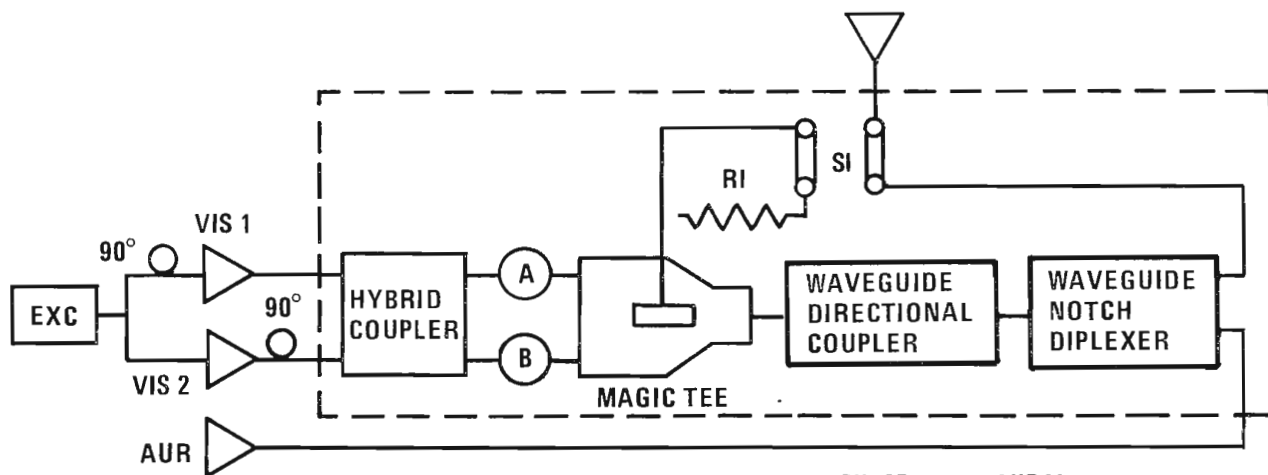

	SWITCHING MODES	PHASE DEGREES		AURAL DETUNER POSITION	S1 POSITION
		A	B		
MODE 1	VISUAL 1 + VISUAL 2 AND AURAL INTO ANT.	0	0	OUT	1
MODE 2	VISUAL 1 AND AURAL INTO ANT. VISUAL 2 INTO TEST LOAD.	-90	0	OUT	1
MODE 3	VISUAL 2 AND AURAL INTO ANT. VISUAL 1 INTO TEST LOAD.	0	-90	OUT	1
MODE 4	VISUAL 1 + VISUAL 2 AND AURAL INTO TEST LOAD.	0	0	OUT	2
MODE 5	VISUAL 1 + VISUAL 2 AURAL/VISUAL MULTIPLEXED THRU NOTCH DIPLEXER INTO ANT.	0	0	IN	1

"Magic Tee" RF Switching Systems



coupler, with the two output ports routed through Phase Shifters A and B to the side arms of the "Magic Tee". Routing of either visual klystron to the antenna or station load is then accomplished by operating the phase shifters appropriately.

Multiplexed operation of either or both visual klystrons requires only detuning of the aural cavities. All of these operations can be performed locally or by remote control and without lengthy program interruption.

The "Magic Tee" system is tuned in the factory for optimum VSWR, and is usually shipped un-

assembled and ready to install, although it can be shipped assembled in a frame package. The optimized system provides a visual VSWR of approximately 1.07.

Flexible "Magic Tee" systems can handle a full range of operational switching functions, including:

### Standard Modes

1. Both Visuals and Aural klystrons to Antenna
2. Both Visuals and Aural klystrons to test load
3. Visual 1 and Aural to Antenna and Visual 2 to test load

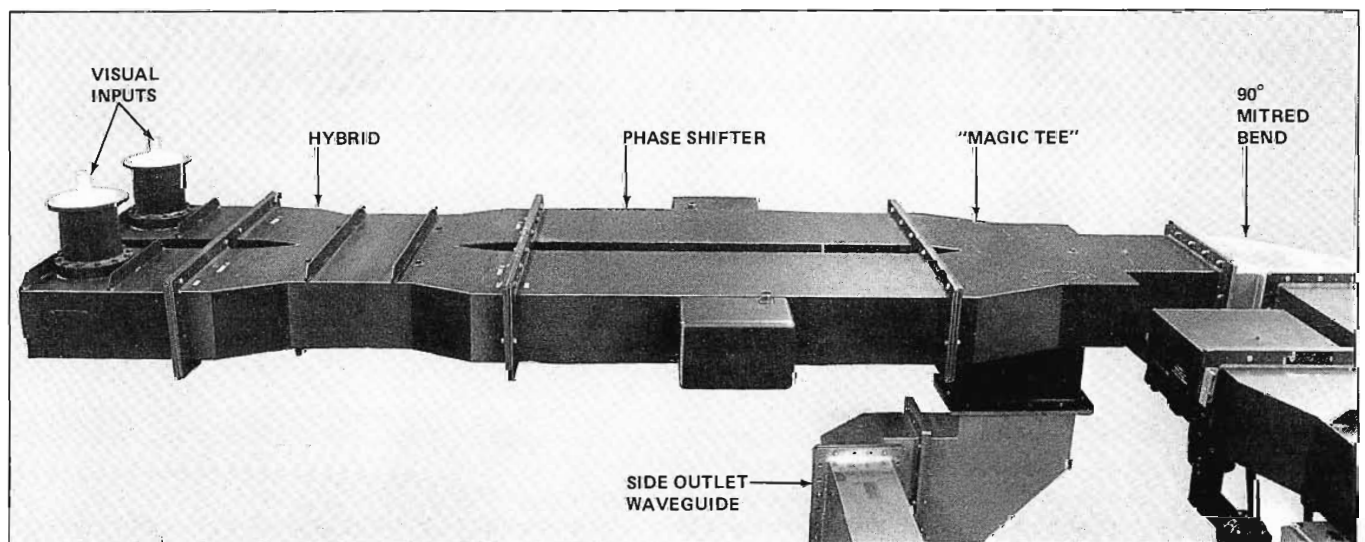
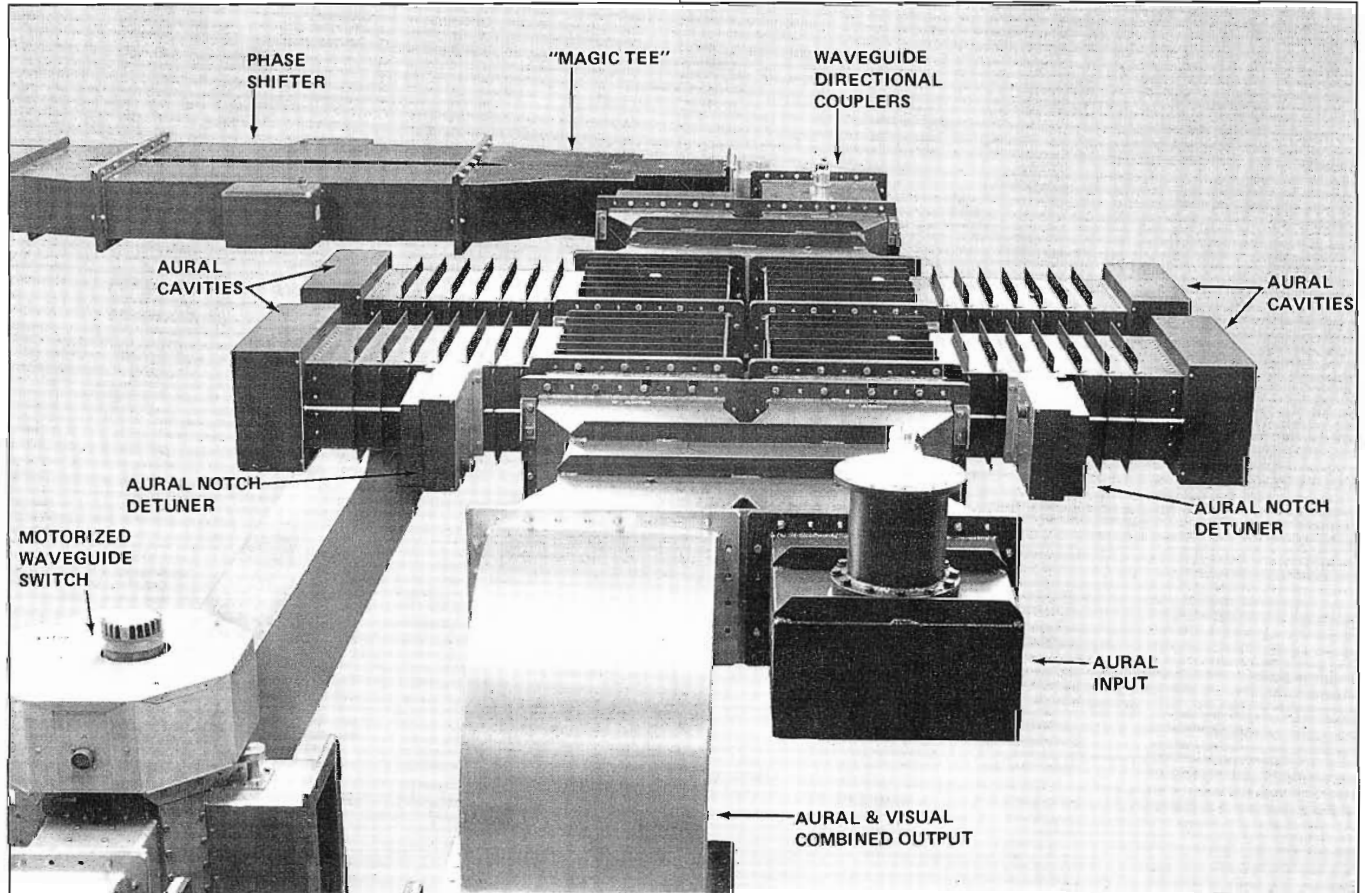

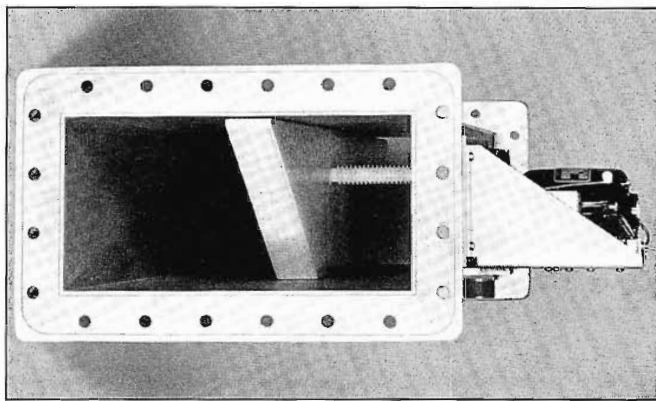

**Phase Shifter**

4. Visual 2 and Aural to Antenna and Visual 1 to test load
5. Visual 1 and 2 multiplexed to Antenna

**Additional Modes**

1. Visual 1 multiplexed to Antenna, and Visual 2 and Aural to test load
2. Visual 2 multiplexed to Antenna, and Visual 1 and Aural to test load
3. Visual 1 and 2 multiplexed to Antenna, and Aural to test load

Accomplishing all of these functions with manual or motorized switching systems would require a combination of 3-port, 4-port or 7-port patch panels, and a complex transmission line lay-

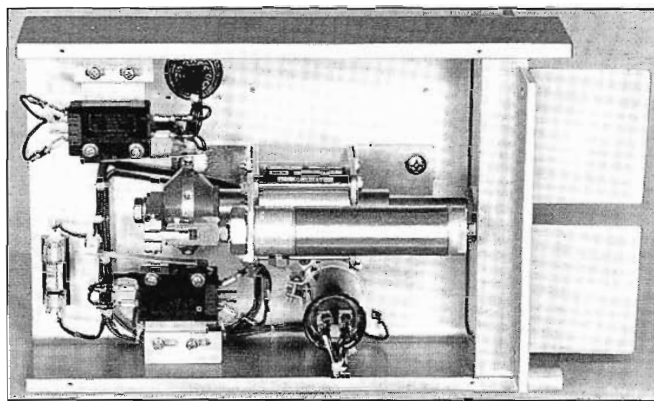

**Aural Cavity Detuner**

out. The "Magic Tee" provides switching flexibility without the mechanical complexity of manual or motorized systems, and with fewer coaxial connections.

While the "Magic Tee" switching system is designed for parallel 60 and 110 kW RCA Transmitters, the Waveguide Notch Diplexer with Aural Cavity Detuners can also be used in single ended TTU-30D and TTU-55C Transmitters. This system permits multiplex operation directly through the notch diplexer. Thus only one 3-port manual patch is required to feed the output of a single ended transmitter to test load or antenna.

## NEW HC-2 HAWKEYE CAMERA



Introduced at NAB, the new HAWKEYE HC-2 portable is compact, lightweight and easy to handle. It is a rugged camera package, including performance and operational features that make it especially suited for demanding ENG/EFP use.

Sturdy cast side covers and a new "T-Bar" handle provide extra protection against the abuses that field cameras are frequently subjected to. The "T-Bar" handle permits easier carrying and handling on location. An integral viewfinder with switchable external talent tally indication has been added.

HC-2 picture quality is excellent, and the signal-to-noise ratio of 58 dB provides sensitivity for effective operation at very low light levels.

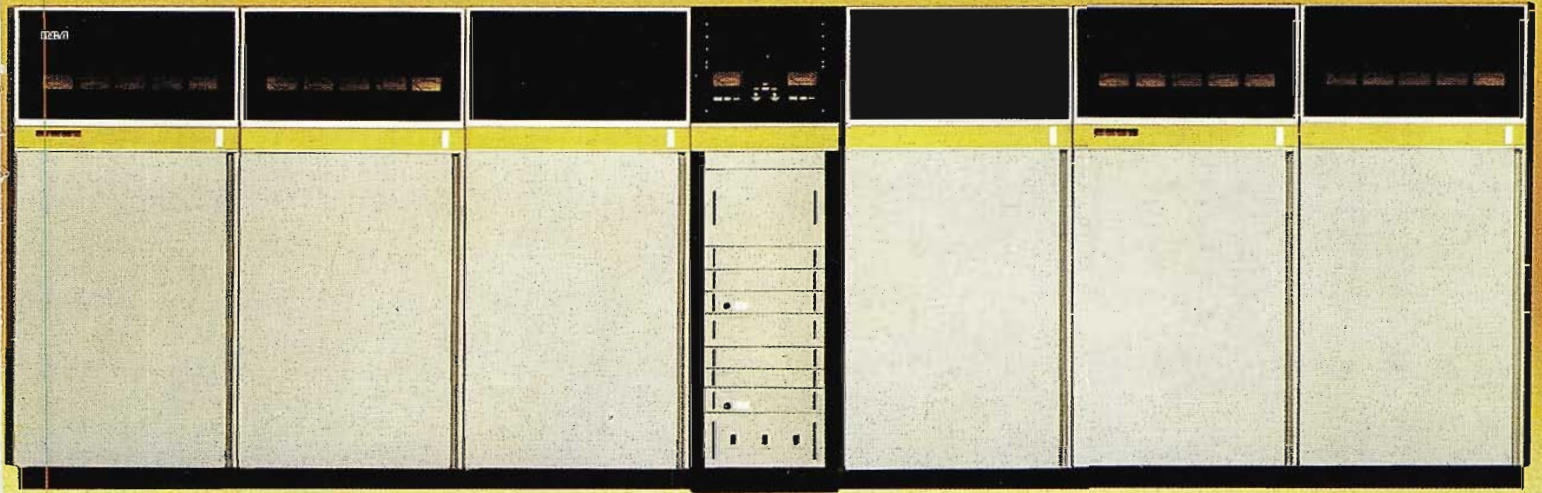

# TTG-SERIES TV TRANSMITTERS 10kW to 100kW-- FOR WORLDWIDE USE

RCA's extensive TTG-Series of VHF television transmitters now numbers 26 different models covering highband and lowband, single-end and parallel systems – in a range of power outputs from 10kW to 100kW.

Designed for worldwide use, TTG transmitters utilize state-of-the-art technology throughout and are available for all video standards: NTSC, PAL and SECAM.

More than 100 of these new generation transmitters are in operation, and field performance results have been excellent.

TTG-Series transmitters are designed for superior picture

and sound quality; high reliability and operating economy. Solid state up to 1600 watts in high power versions, the transmitters employ only two tubes – an aural and a visual. There are a minimum of tuning controls, and the broadband driver has no tuning controls. A new exciter-modulator system features programmable synthesized frequency generation to achieve system performance approaching total signal transparency.

Other major features include:

- Incidental Carrier Phase Modulation (ICPM) correction
- Superior low level Surface Acoustic Wave (SAW) sideband shaping

- Solid state control logic and protection circuitry
- Unattended operation

Innovative, performance-proven TTG-Series transmitters are meeting worldwide operating standards and establishing new levels of technical achievement without compromise in quality.

See your RCA Representative soon for complete and compelling technical data. Or write: RCA Broadcast Transmission Systems, Building 2-2, Camden, NJ 08102.

## RCA



**KCOP-TV's HAWKEYE  
Recording Camera  
reaches above crowd for  
close-up action coverage**

